

# Pottery finds from hermitage EE.50 in Naqlun. Preliminary assessment of the assemblage

Katarzyna Danys

Polish Centre of Mediterranean Archaeology, University of Warsaw

**Abstract:** Rescue excavations undertaken in hermitage EE.50 in Naqlun in 2016 brought to light an extensive pottery assemblage composed of red-slipped goblets, bowls and plates of Egyptian origin, made of alluvial fabrics, and a few specimens imported from North African workshops. The repertoire of tableware was complemented with *qullae* made of marl and alluvial clays. Numerous cooking pots, pans and a single lid represent kitchen equipment. Goods were kept in large vessels of different types. Commodities such as wine, olive oil or fish sauce were delivered in amphorae: Egyptian LRA 7 and imported vessels, originating from North Africa (Tunisia), Cilicia, Cyprus and Rhodes(?). This assemblage has revealed some aspects of everyday life in the hermitage and confirmed the independent self-sufficient lifestyle of its inhabitants. The pottery assemblage is from the middle to the end of the 5th century AD.

**Keywords:** Egypt, late Roman, 5th century, Naqlun, hermitage, pottery, amphorae, tableware, imports

Hermitage EE.50 is one of the complexes located in the hills to the west of Deir el-Naqlun, investigated by the Polish team following recent serious damage to its substance as a result of illicit digging (for the archaeological report, see Godlewski 2017, in this volume). The investigations revealed a pottery assemblage that was dumped outside the hermitage structures by the unknown diggers and hence can be associated only generally with EE.50. Yet it was deemed worthwhile to report on the find in view of the largely cooking character of this set.

The assemblage was analyzed using the quantification method, counting all diagnostic pieces: rims, bases and handles as well as body sherds (RHBS). Body fragments joined to rims, bases or handles were all deemed diagnostic. A pottery corpus was compiled on these grounds. The minimum vessel count (VMI) method was implemented. The assemblage comprised tableware, including some miscellaneous ceramic objects like a lid and an incense burner, cooking vessels and storage containers as well as amphorae.

## TABLEWARE

The tableware group consisted of red-slipped vessels of local production (Hayes Egyptian Red Slipped B), and two specimens imported from North Africa. The repertoire comprised at least three goblets, six bowls, two carinated bowls, ten plates and five *qullae*.

Ledged-body GOBLETS, e.g., Nd.16.150 [Fig. 1] were made of alluvial fabric and find numerous parallels among vessels previously discovered in other Naqlun hermitages: EE.25 (Godlewski, Derda, and Górecki 1994: Figs 22.6–12), EE.6 (Godlewski, Danys, and Maślak 2016: Fig. 16:Nd.15.017), EW.87 (personal

observation, unpublished), as well as in the monastery rubbish dump (Danys-Lasek 2014: Fig. 6:323; 2012: Fig. 4:Nd.08.757). These examples span a time range from the 5th to the 7th century AD.

DEEP AND NECKED BOWLS have globular or angled shoulders, e.g., Nd.16.135 and rounded lower parts, e.g., Nd.16.149 [see Fig. 1]. They are made of hard or soft alluvial fabric. The latter bore a white-painted, wavy band on its shoulders. Forms analogous to Nd.16.135, dated from the beginning to the mid-5th century AD, have also been found in hermitage EW.87 (personal observation, unpublished).

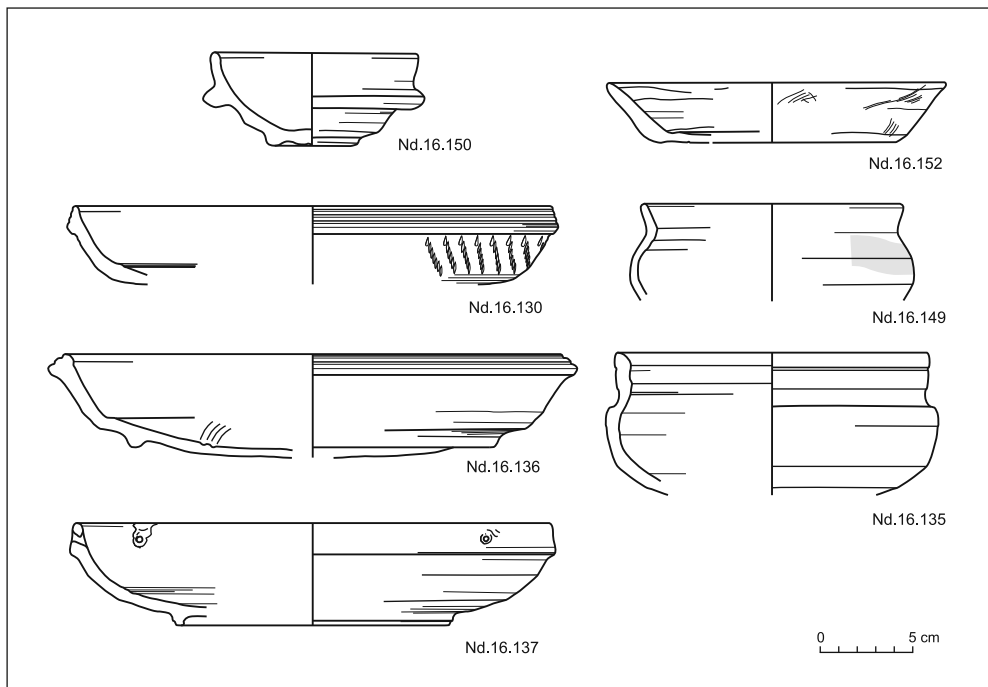
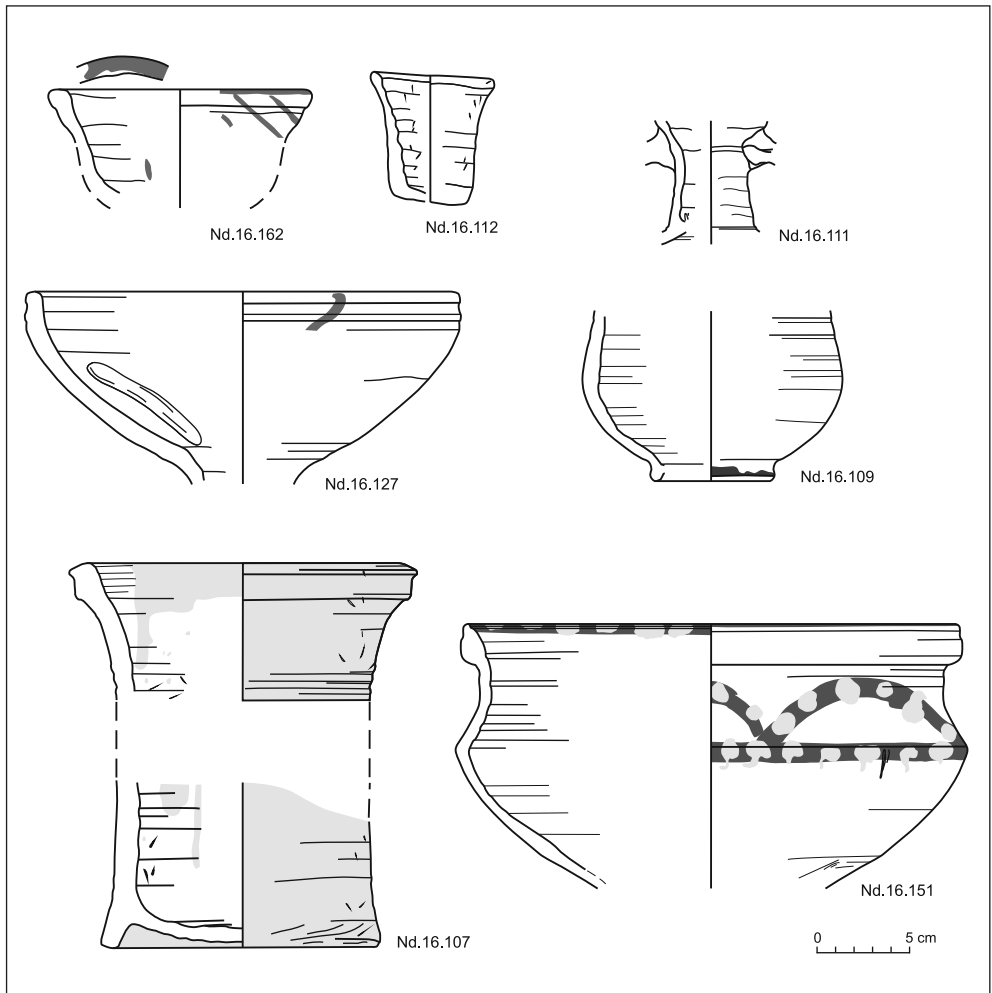

Fig. 1. Tableware selection: plates Nd.16.130, Nd.16.136, Nd.16.137; bowls Nd.16.135, Nd.16.149, Nd.16.152; goblet Nd.16.150 (only Nd.16.130 not of Egyptian production) (All PCMA Naqlun Project/drawing K. Danys)

SHALLOW AND NECKLESS BOWLS have rounded rims, sometimes with a ridge below on the outside, plain walls and flat bases, e.g., Nd.16.152 [see *Fig. 1*]. These bowls were made of a hard, alluvial fabric. One specimen bore traces of burning on the floor, suggesting that it may have been

used as a lamp. A similar shape of bowl was recorded in Pelusium (Ballet 1997: Pl. II:25).

CARINATED BOWLS were rather large and deep, made of soft alluvial fabric, e.g., Nd.16.151, characterized by painted decoration: a black rim band and black



*Fig. 2. Selection of tableware: top left, incense burner Nd.16.162 and bell-shaped cup Nd.16.112; center left, funnel Nd.16.127; bottom left, pot-stand Nd.16.107; top right, qullae Nd.16.108a, Nd.16.111; bottom right, carinated bowl Nd.16.151*

arcades on a horizontal band in the upper part, all embellished with rows of white spots [Fig. 2].

PLATES included Egyptian and imported items. The latter were represented by two specimens of the same type: ARSW Hayes 84, manufactured in Tunisia around AD 440–500 (Hayes 1972: 133, Fig. 23). They have a down-turned ('Samian') rim with grooves on it and rows of rouletting on the external body surface, e.g., Nd.16.130 [see Fig. 1]. Parallels for these plates were also found at Kellia (Bonnet Borel and Cattin 2003: Fig. 410:7). Locally-made plates belonged to four types, distinguished on the grounds of rim shape, including a bead and grooved rim, e.g., Nd.16.136 [see Fig. 1], a down-turned rim, e.g., Nd.16.137 [see Fig. 1], a plain rim and a rounded rim with ledged body. Preserved bases have the form of a low ring. One specimen was decorated with engraved grooves on the rim and floor (Nd.16.136) and another (Nd.16.137) had a single post-firing hole pierced just below the rim, which does not seem to be a repair hole as there were no others on at least half of the vessel (preserved 50% of the circumference). It may have been for some handling device, like a cord laced between two holes on the opposite sides of the rim to make a handle (assuming there was another hole on the unpreserved part of the vessel), perhaps to protect the content against small animals or insects. Such a way of closing a vessel has parallels among the finds from Karanis (Johnson 1981: Pl. 7:60) and Nd.16.137 is similar to examples from Kellia (Bonnet Borel and Cattin 2003: Fig. 411:36).

At least three QULLAE of marl clay were distinguished, probably representing

two different forms, one with globular or slender shoulders and the other with a pear-like bottom shape, e.g., Nd.16.108a [Fig. 2]. The narrow neck of Nd.16.111 [see Fig. 2] was equipped with a partly preserved filter. At least two items were made of alluvial fabric, cream-slipped on the outside. Small fragments of shoulder bore black and red decoration, unfortunately poorly preserved. However, it seems to be the same as the decoration recorded on the vessels from hermitages EE.6 (Godlewski, Danys, and Maślak 2016: Fig. 16:Nd.15.056, Nd.15.053) and EW.87 (unpublished).

MISCELLANEOUS VESSELS from the tableware category include some singular specimens of uncommon form [see Fig. 2]. An outstanding small, bell-shaped cup Nd.16.112 was made of alluvial fabric and its coarse surfaces had no slip. A partly-preserved incense burner Nd.16.162 of alluvial fabric, very poorly fired, was coated with cream slip, and traces of purple-painted linear decoration were observed on the rim and on the outside. The upper part of funnel Nd.16.127 was cream-slipped on the outside, and some traces of black-painted decoration were also observed on the exterior. A similar example, although undecorated, was recorded in Kellia (Bonnet Borel and Cattin 2013: Fig. 59:59). Last but not least, there was a cylindrical vessel, presumably a pot-stand(?) Nd.16.107, made of a hard, alluvial fabric, white-slipped on the outside and with drips and splashes inside on the grey surface. An analogous object was found in hermitage EW.87 in Naqlun (personal observation, unpublished).

## COOKING EQUIPMENT

At least seven vessels were identified as cooking pots [Fig. 3]. All of the pots represented deep and closed forms, made of different alluvial fabrics. External surfaces were covered with red slip. The most common were necked forms, e.g.,

Nd.16.121, which has a white-painted band on the inside rim, being rather unusual for pots in this group. Other cooking equipment from the hermitage included at least two rather shallow pans, with ledge- or down-turned rims, ribbed

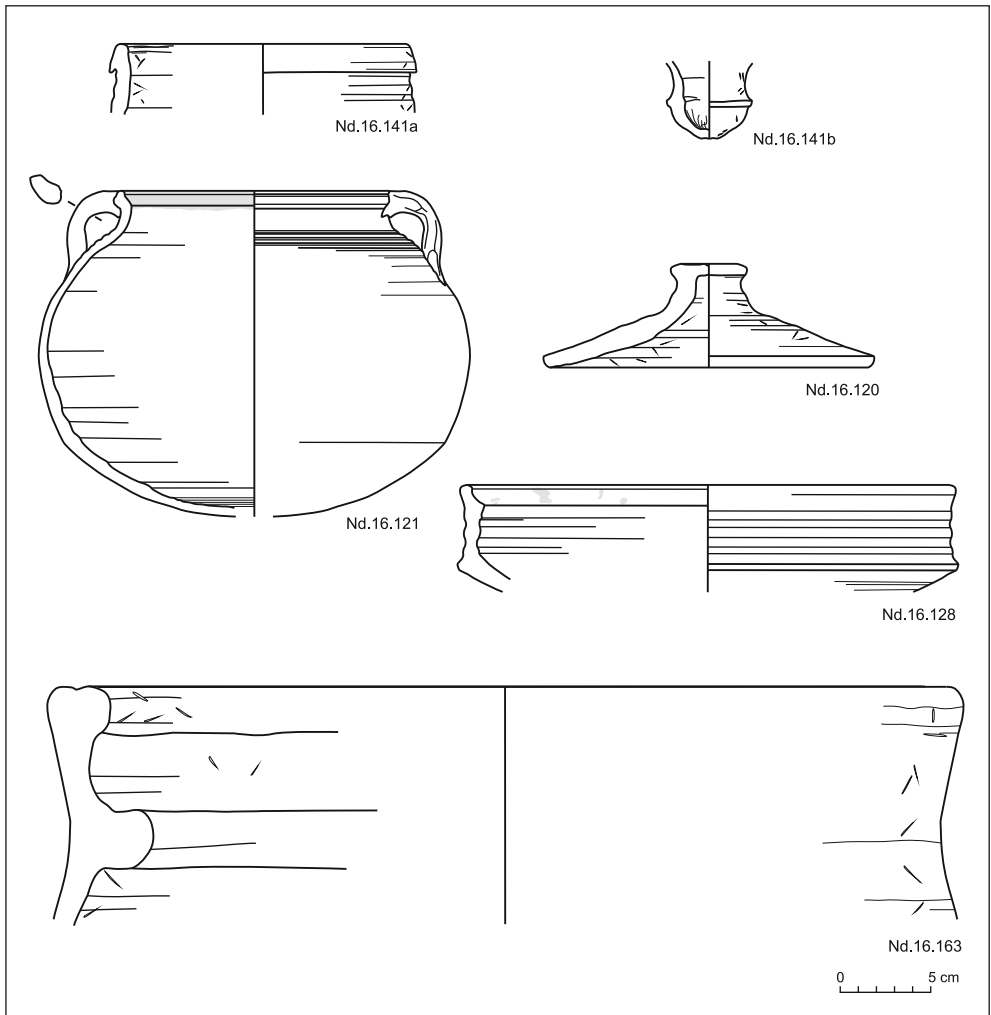

Fig. 3. Selection of cooking pots (Nd.16.120, Nd.16.121, Nd.16.128) and storage vessels (Nd.16.141a–b, Nd.16.163)

upper parts and sharp carination in the middle. Both were made of alluvial fabric and were red-slipped, but only Nd.16.128 had cream-painted splashes on the rim. These forms were paralleled in Kellia by type E85, which was connected with a context of the early 5th century AD (Egloff 1977: Pl. 43:16), and by similar vessels in Karanis (Johnson 1981: Pl. 68:52B). Last but not least, there was a lid Nd.16.120, made of the same fabric and with the same kind of surface treatment as the cooking pots. It has a rounded rim, plain walls, a knobbed handle and bears traces of heavy burning.

Pottery for cooking purposes from EE.50 was similar to groups coming from the other hermitages in Naqlun, e.g., hermitages EW.87 and EE.6. Saucepans were the one exception: deep, closed forms of a circle segment (for the shape, see the example from EE.6 in Godlewski, Danys, and Maślak 2016: Fig. 17:Nd.15.064). None of the fragments discovered in EE.50 could be identified with this group. Could this be connected with the culinary methods used by the inhabitants of this hermitage? Of note is the fact that unlike the pans, the cooking pots and the lid bore traces of use (burning and sooting).

## STORAGE VESSELS

The smallest group amongst the pottery from EE.50 was composed of vessels and containers used for storage purposes [see Fig. 3]. At least two *qawwadis* can be distinguished (e.g., Nd.16.141, parts a and b). Besides their primary function as *saqqiya* pots, they might have been used for transporting water to the hermitages, a practical solution in the case of the hill hermitages in Naqlun where goods, including pots full of water could have been transported by donkey trains. *Qawwadis* may have also been used for storing water.

The shape of the base of the specimen from EE.50 is noteworthy: the ledged knob, round-ended and hollow interior

finds parallels in the material from hermitage EW.87 (personal observation, unpublished) from the early to mid 5th century AD, as well as in Tod, dated there to the end of the 5th–mid 7th century AD (Pierrat 1996: Fig. 97), and in el-Ashmunein from the 6th to the mid-7th century AD (Bailey 1998: Pl. 48: H94). The most numerous in this group were large, coarse, wheel-made containers (e.g., Nd.16.163), made of alluvial fabric. Others were handmade, but unfortunately poorly preserved (for a complete handmade large storage vessel, see the example from EE.6 in Godlewski, Danys, and Maślak 2016: Fig. 17:Nd.15.060).

## AMPHORAE

Most of the pottery finds belonged to the LRA 7 amphora type (Riley 1979: 225–226) [Fig. 4] and the count of preserved bases indicated that at least 84 containers were present. They represented different states of preservation: the

eroded surface on many suggested long exposure to weather conditions (e.g., Nd.16.103), while those that were almost complete, with only the lower part broken, were most probably reused in (other) structures, e.g., in wall construction.

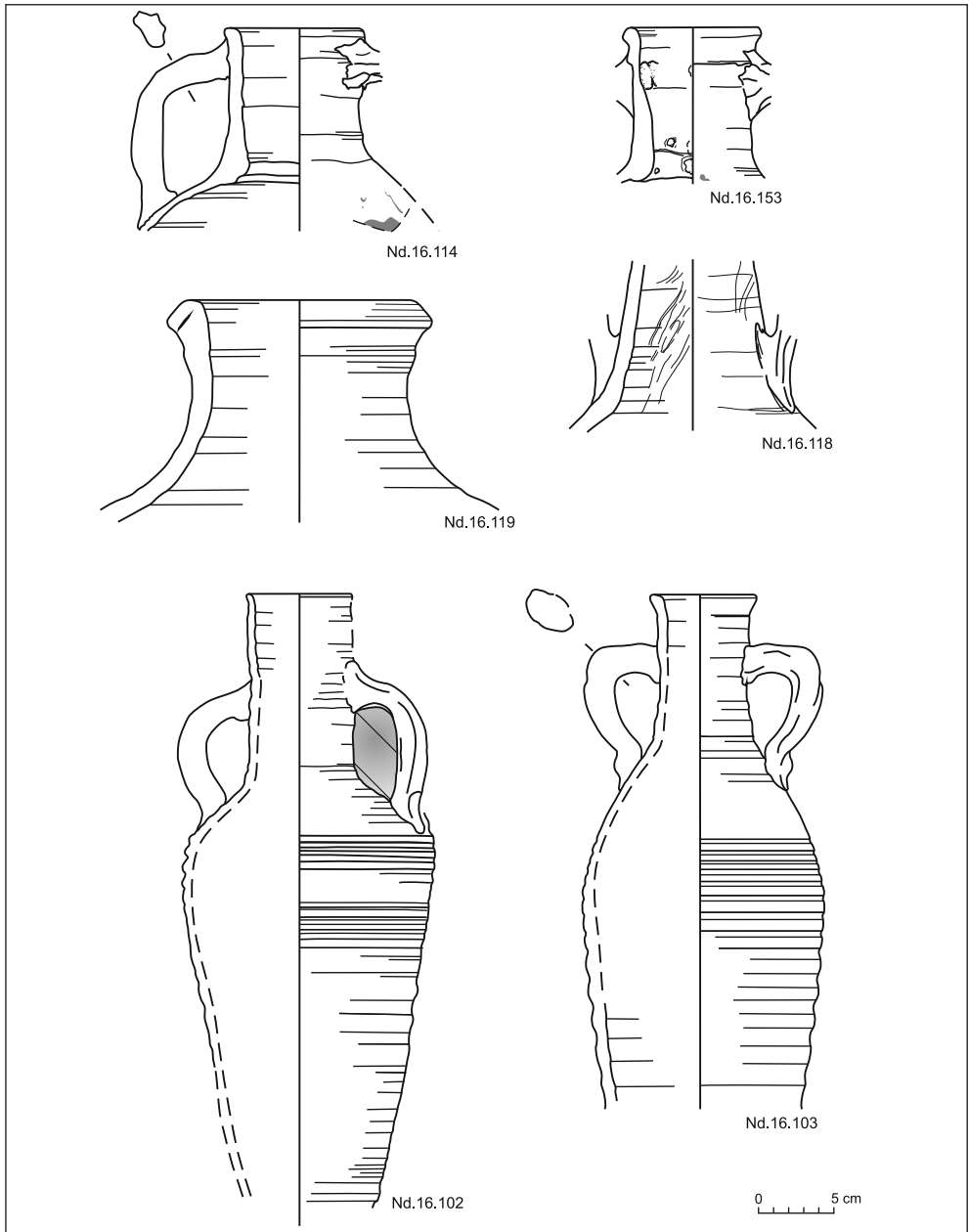

Fig. 4. Selection of amphorae: Cilician and Cypriot LRA 1 (Nd.16.115, Nd.16.143), North African Tripolitania III (Nd.16.119) and LRA Benghazi 8 (Nd.16.118) and Egyptian LRA 7 (Nd.16.102, Nd.16.103)

Traces of mortar noted on the surfaces support this theory (e.g., Nd.16.102). Moreover, the discovery of a wall built in the courtyard of the recently excavated hermitage EE.6 showed amphorae *in situ* as part of the construction. The group of amphorae of type LRA 7 consisted of one general type, E177, according to Michael Egloff's typology (1977: 116, Pl. 59:7), or AE7.1-1 variant A in Delphine Dixneuf's nomenclature (2011: 163–164, Fig. 152). The characteristic elements of these vessels comprise elongated necks, everted rims, rather slender bodies with strong ribbing on the shoulders, while the bases are elongated and twisted or have icicle-like shapes. Specimens found in EE.50 were made of fine Nile fabrics with two main sets of inclusions: quartz with mica flakes and white particles (limestone?), and quartz with carbonated organics and abundant mica. It seems that LRA 7, made of the first fabric group, might be connected with pottery workshops located close to Fayum Oasis, such as Oxyrhynchos (Behnasa), and the other type with Hermopolis Magna (el-Ashmunein), as the large amount of mica and white particles appearing in the clay here might suggest this location (Dixneuf 2011: 157, Fig. 181). Amphorae of type LRA7 represented the earliest types, dated by Dixneuf to the second half of the 4th through the 5th century AD, but other scholars propose a chronology in the 5th–6th century AD for finds from el-Ashmunein and Kom el-Nana (Bailey 1998: 132, Pl. 79: VI; Pyke 2005: Fig. 4.5 KN4). In Naqlun, such specimens were also discovered in other hermitages, such as EE.6 and EW.87, connected with the 5th–6th century AD horizon. They were also recorded at Soknopaiou Nesos (Dixneuf 2012: Cat. 44–54) and Oxyrhynchos

(Subías Pasqual 2007: Pl. 1, Fig. 5) with the same dating.

Among the group of imported LRA Carthage 1 amphorae [see *Fig. 4* top row] at least four items can be distinguished. Macroscopic analysis of the fabrics and their comparison to those from identified production centers (Williams 2005) allowed three different places of origin of these amphorae to be distinguished: Cilicia (e.g., Nd.16.114), Cyprus (e.g., Nd.16.153) and, most probably, Rhodes. The Cilician container bore a fragmentary red *dipinto* on its shoulder. A characteristic feature of Nd.16.153 was the presence of large white particles (limestone?) erupting to the inner surface. It seems that LRA Carthage 1 fragments from hermitage EE.50 represent an early production phase of containers of this type, and are widely dated to the 5th century AD (Pieri 2005: 71). With regard to their content, olive oil as well as wine can be taken into consideration (Peacock and Williams 1986: 187; Pieri 2005: 85).

Cylindrical amphorae of North African origin [see *Fig. 4*: Nd.16.119, Nd.16.118] were represented by at least three specimens belonging to two different types: LRA Carthage 7, also labeled as Tripolitania III or Keay XXIV (henceforth called Tripolitania III) and LRA Benghazi 8. The former, Nd.16.119, was a fragment of a massive, thickened and everted rim with its exterior in greenish-cream coating. Its origin can be identified in the province of Tripolitania (now southeastern Tunisia and western Libya), where kiln sites have been located. It seems that the Naqlun example was manufactured in a Tunisian workshop located at the Zitha/Zian site (Bonifay 2004: 29). The possible contents were olive or oil (Bonifay 2005; Ballet, Bonifay,



and Marchand 2012: 104). Amphorae of this type occurred between the 2nd and 4th century AD (Bonifay 2004: 105; Peacock and Williams 1986: 170), but there are also some examples, like those discovered on Catalan sites (Keay 1984: 393, Fig. 75:2), dated to the 4th through mid-5th century AD or to AD 430–440 in the case of a specimen found in Rome (Bonifay 2005). Two other items recorded in hermitage EE.50 were fragments of necks (e.g., Nd.16.118), belonging to LRA Benghazi 8 (Peacock and Williams class 51), the 'spatheion' type (Riley 1979) and these represent the larger (variant B) version of those containers. These finds were, most probably, manufactured in northern Tunisia, and a macroscopic

analysis of the fabric of the Naqlun specimens suggests that it is similar to the material from northern Tunisia (Keay 1984: 447). The chronology of finds of this type discovered in the western Mediterranean spans the 5th and 6th centuries AD (Keay 1984: 394). Narrow and smaller forms (variant A) are dated to the late 4th century, possibly through the 6th century AD (Peacock and Williams 1986: 203); these occurred in Naqlun, in a rubbish dump on the kom, in layers connected with the 6th century AD. Larger forms (variant B) were recorded in hermitage EW.87 (personal observation, unpublished), dated to the beginning through mid-5th century AD. The principal contents of LRA Benghazi 8 remain unknown, but olive oil is possible.

## CONCLUSIONS

The assemblage of pottery collected from hermitage EE.50 was homogenous with respect to vessel types. It replicates the repertoire of vessels from hermitages excavated previously, such as EE.6 and EW.87. The semi-anchoretic character of structures from the Naqlun *laura* is attested by the pottery. Vessels for storage purposes, including large ones, seem to have been an integral part of the hermitage equipment allowing for the self-sufficiency of the inhabitants.

Numerous vessels for cooking purposes came from kitchen facilities and are well known from other Naqlun eremitic complexes. Interestingly, saucepans did not appear in this assemblage, although they were registered among the finds from hermitages EE.6 and EW.87. It remains to be seen whether this was a coincidental choice of cooking vessels or a reflection of cooking techniques and food preferences.

Tableware was composed of locally made plates, bowls and goblets with a small addition of imported vessels manufactured in North Africa, most probably in Tunisia. The absence of Aswan Ware was also conspicuous, considering that vessels of this kind have been recorded in other hermitages in Naqlun.

The presumed self-sufficient lifestyle of the inhabitants of EE.50 is borne out also by the commodities delivered in the amphorae. The most numerous are LRA 7 vessels which represent the earliest examples of this type. Their elongated necks are reminiscent of those of their predecessors, of type AE3 in Dixneuf's typology, the local origin of which in the southwestern part of Fayum is certain (Bailey 2007). The most likely content was wine, but other things, such as fish sauce, can be considered as well. Other amphorae collected from hermitage EE.50

were preserved only in fragments; these were imported Tripolitanian III, LRA Benghazi 8 from North Africa (Tunisia) and LRA Carthage 1 from Cilicia, Cyprus or Rhodes(?). Most probably they were used for olive oil transportation.

This pottery assemblage seems to be placed in the mid 5th century AD, continuing through the end of the 5th century AD. The closest parallels for the tableware types came from other hermitages of early 5th century date. Moreover the quantity and appearance of specific amphorae types, their parallels and chronology at other archaeological sites also suggest this date.

The group of transport containers from EE.50, as well as from hermitages EE.6 and EW.87 revealed significant differences from the materials discovered on the southern

refuse dump of the kom in Naqlun. The earliest layers there, of the 6th century AD(?), yielded no large cylindrical African amphorae, although a narrow version of the LRA Benghazi 8 'spatheion' type was registered. Last but not least, amphorae of an early type of LRA 7 with elongated neck differed from those recorded from the monastery ruins on the plateau and represented mainly AE7.1-1 in Dixneuf's typology, which opts for a date in the second half of the 4th through the 5th century AD (Dixneuf 2011: Fig. 159). In summary, the collection of pottery from hermitage EE.50 should be dated to the mid through end of the 5th century, which allows this complex to be identified as one of the earliest eremitic foundations in the hills of Naqlun.

Katarzyna Danys

Polish Centre of Mediterranean Archaeology, University of Warsaw  
00-497 Warsaw, Poland, ul. Nowy Świat 4  
katarzyna\_danys@o2.pl

## REFERENCES

- Bailey, D.M. (1998). *Excavations at el-Ashmunein V. Pottery, lamps and glass of the late Roman and early Arab periods*. London: British Museum Press
- Bailey, D.M. (2007). A form of Amphores Égyptiennes 3 from the South-West Fayum. In S. Marchand and A. Marangou (eds), *Amphores d'Égypte de la Basse Époque à l'époque arabe I* [=CCE 8/1] (pp. 227–237). Cairo: Institut français d'archéologie orientale
- Ballet, P. (1997). Péluse. Le théâtre romain. *CCE*, 5, 109–121
- Ballet, P., Bonifay, M., and Marchand, S. (2012). Africa vs Aegyptus: routes, rythmes et adaptations de la céramique africaine en Égypte. In S. Guédon (ed.), *Entre Afrique et Égypte relations et échanges entre les espaces au sud de la Méditerranée à l'époque romaine* [=Scripta Antiqua 49] (pp. 87–117). Bordeaux: Ausonius
- Bonifay, M. (2004). *Études sur la céramique romaine tardive d'Afrique* [=BAR IS 1301]. Oxford: Archaeopress

- Bonifay, M. (2005). Tripolitanian 3. In *Roman amphorae: a digital resource*. Retrieved from [http://archaeologydataservice.ac.uk/archives/view/amphora\\_ahrb\\_2005/details.cfm?id=306&CFID=71280&CFTOKEN=FE615FF0-49B9-4555-BCF324A6B1C440B5](http://archaeologydataservice.ac.uk/archives/view/amphora_ahrb_2005/details.cfm?id=306&CFID=71280&CFTOKEN=FE615FF0-49B9-4555-BCF324A6B1C440B5) [accessed: 22.04.2016]
- Bonnet Borel, F. and Cattin, M.-I. (2003). Le matériel archéologique. In P. Bridel and D. Sierro (eds), *EK 8184 IV. Explorations aux Qouçouÿr Hégeila et Éreima lors des campagnes 1987, 1988 et 1989* (pp. 437–642). Leuven: Peeters
- Danys-Lasek, K. (2012). Pottery from the refuse dump under unit B.26 in Naqlun. *PAM*, 21, 222–232
- Danys-Lasek, K. (2014). Pottery from Deir el-Naqlun (6th–12th century). Preliminary report from Polish excavations in 2010 and 2011. *PAM*, 23/1, 543–642
- Dixneuf, D. (2011). *Amphores égyptiennes: production, typologie, contenu et diffusion, III<sup>e</sup> siècle avant J.-C – IX<sup>e</sup> siècle après J.-C.* [=Études Alexandrines 22]. Alexandria: Centre d'études alexandrines
- Dixneuf, D. (2012). Introduction à la céramique de Soknopaiou Nesos. In M. Capasso and P. Davoli (eds), *Soknopaiou Nesos project I. 2003–2009* [=Biblioteca degli "Studi di egittologia e di papirologia" 9] (pp. 315–361). Pisa: F. Serra
- Egloff, M. (1977). *Kellia, la poterie copte: quatre siècles d'artisanat et d'échanges en Basse-Egypte I–II* [=Recherches suisses d'archéologie copte 3]. Geneva: Georg
- Godlewski, W. (2017). Naqlun 2016. Hermitage EE.50: preliminary report. *PAM*, 26/1, 161–172
- Godlewski, W., Danys, K., and Maślak, S. (2016). Deir el-Naqlun 2014–2015. Preliminary report. *PAM*, 25, 265–288
- Godlewski, W., Derda, T., and Górecki, T. (1994). Deir el Naqlun (Nekloni), 1988–1989. Second preliminary report. *Nubica*, 3(1), 201–263
- Hayes, J.W. (1972). *Late Roman pottery*. London: British School at Rome
- Johnson, B. (1981). *Pottery from Karanis: Excavations of the University of Michigan* [=Kelsey Museum of Archaeology Studies 7]. Ann Arbor, MI: University of Michigan Press
- Keay, S.J. (1984). *Late Roman amphorae in the Western Mediterranean: A typology and economic study. The Catalan evidence I* [=BAR IS 196/1]. Oxford: British Archaeological Reports
- Peacock, D.P.S. and Williams, D.F. (1986). *Amphorae and the Roman economy: An introductory guide*. London: Longman
- Pieri, D. (2005). *Le commerce du vin oriental à l'époque byzantine, V<sup>e</sup>–VII<sup>e</sup> siècles: le témoignage des amphores en Gaule* [=BAH 174]. Beirut: Institut français du Proche-Orient
- Pierrat, G. (1996). Évolution de la céramique de Tôd. Du II<sup>e</sup> au VII<sup>e</sup> siècle apr. J.-C. *CCE*, 4, 189–214
- Pyke, G. (2005). Late Roman Egyptian amphorae from squares U and V at Kom el-Nana. In J. Faiers, *Late Roman pottery at Amarna and related studies* [=EES Excavation Memoirs 72] (pp. 213–244). London: Egypt Exploration Society
- Riley, J.A. (1979). Coarse pottery. In J.A. Lloyd (ed.), *Excavations at Sidi Khrebish, Benghazi (Berenice) II* [=Libya Antiqua Supplements 5] (pp. 91–467). Tripoli: Department of Antiquities, People's Socialist Libyan Arab Jamahirya

- Subías Pascual, E. (2007). Notice sur les amphores tardives d'Oxyrhynchos. In S. Marchand and A. Marangou (eds), *Amphores d'Égypte de la Basse Époque à l'époque arabe I* [=CCE 8/1] (pp. 297–308). Cairo: Institut français d'archéologie orientale
- Williams, D.F. (2005). An integrated archaeometric approach to ceramic fabric recognition: A study case on late Roman amphora 1 from the eastern Mediterranean. In J.M. Gurt i Esparraguera, J. Buxeda i Garrigós, and M.A. Cau Ontiveros (eds), *LRCW1. Late Roman coarse wares, cooking wares and amphorae in the Mediterranean: Archaeology and archaeometry* [=BAR IS 1340] (pp. 613–624). Oxford: Archaeopress