

Ahmet KARAARSLAN, Tolga ÖZER

Afyon Kocatepe University, Faculty of Technology, Department of Electrical-Electronic Engineering, Afyonkarahisar, Turkey

Application of wireless audio transmission circuit using laser technology

1. Introduction

Laser technology has been shown important developments recently, and we can see this technology in lots of significant fields [ZHANG Linhua, YANG Yongqiang, LAI Kexian 2005]. Especially, the main fields of laser technology used in military fields, electronic and computer field, aviation field, medicine field and manufacturing industry [Clark 1981; Fermann 2009].

The basis of laser which is based on the principle of the theory of induced radiation suggested by Albert Einstein at 1916. According to this Einstein's theory when induced radiation energy level of an atom come down lower energy level than beginning this atom have to propagate photons. The consequence of this energy occurs [Einstein 1972].

MAZER is based on this theory which had put forward by Albert Einstein. MAZER was found in 1950's by Colombia University's staff Charles H. Townes who used ammonia. MAZER's principle is based on increasing microwaves with using ammonia. MAZER is occurred by „Microwave Amplification by Stimulated Emission of Radiation” English words initials. It means that microwave upgraded with stimulation of radiation propagation [Lamb, Retherford 1950].

After the finding Mazer, scientists began to study on the applicability of the optical region and result of it they laid the foundations related to study of laser.

At first in 1958's, essential process and physical conditions had been suggested by C. Townes and A.L. Schowlow. As a result of it laser technology quickly began to develop.

The first laser which running with ruby was found by Theodore H. Maiman in 1960. November of the same year P.P. Sorokin and M.J. Stevenson developed first uranium laser also 1960's in 12 December. Helium-neon laser was found by Ali Javan, William R. Bennett and Donald Herriot in Bell laboratory. In 1963 carbon dioxide laser was found by C. Kumar and N. Patel. In the year of 1964 Nd:YAG laser was found by Joseph Geusic, H.M. Marcos and Le Grand Van Uiltert and also this year argonion laser was found by William Bridges. In the result of quickly developing laser technology a lot of kinds of laser have been

developed to the present day. These lasers are different from each other in application fields, owing to used wavelengths, used kind of active materials, according to the energy efficiency and according to the shape of the energy application.

Laser which to be in human life begun to comprise big field. Anymore thanks to laser in eye surgery save to people required to use glasses. Alike CD player came with DVD players to our houses, thanks to laser printers photography moved in from dark room to computer world.

Laser in our life has a big importance and it settled in our life like a daily goods. For example; before a teacher used ruler for signing something but now the teacher use mini laser for it. Also lasers began to take part in children car. Mentioned laser's power is very low degree [Slusher 1999].

In this study general information will be given about lasers and will be given information about wireless audio transmission circuit [Ming, Kwan 2006].

2. Laser technology

Laser means that to getting very high intense coherent and only color light with optical system. At first mechanisms which are improved in microwave field by C.H. Townes called Microwave Amplification by Stimulated Emission and Radiation. The briefly called MASER which obtained with using first letters Microwave Amplification by Stimulated Emission and Radiation words. MASER was changed as a LASER by T.H. Miaman in 1960. LASER was named that using Light Amplification by Stimulated Emission of Radiation words' first letters. Laser is optical sources that created photons compatibility as a beam shape [Hermann Haken 1983; Hetch 2010].

Laser which is a source propagate light beam as an appropriate cluster and laser consists as a result of atoms pumped until beginning to spread light. And this light reinforces quietly with mirror tricks. A laser is a device which produces coherent and dense light in high energy levels with stimulated electronic or molecular transition. The „coherent” mean is that all light waves have same phase. In practice a laser device occurs with medium which located between optical resonator gap's end mirrors. There is coherent light which can rebound between end mirrors when in this medium which have the majority of active atoms are pumped from normal level of energy to higher level of energy in a type will consist of residential conversion. This event causes that this light can reach threshold point. In this way device begin to propagate laser light [Hermann Haken 1983; Siegman 1986].

2.1. Properties of Laser Light

The properties of laser light can be given as follows:

1. Laser light is more dense and violent than normal light source.
2. Normal light disperses in anywhere while Laser light does not disperse and it can be focused. Laser light is has almost any deviation.
3. Laser light has one wave length. Due to this property it has monochromatic feature.
4. Laser light has one color and it has same phase waves.
5. It can be done very sensitive process at high energy level with laser light [Hermann Haken 1983].

2.2. The Principle of Laser Application

The tube that is taken transparent in optically one of its side fully glazed mirror and other side half glazed mirror. This tube filled with gas, solid and liquid matters. The energy which handle with exposed outside light, flowed electric current or handle of energy with chemical way reach to atoms which in medium. Some of these atoms absorb this energy. Over energy make atoms unstable. The atom which is clashed by another atom, unstable and stimulated atom give it's over energy by propagate photons. The photons which reach end come back by means of mirrors. And even to continue [Svelto 1998; Paschotta 2007; <http://www.bgu.ac.il/~glevi/website/Guides/Lasers.pdf>, „Introduction to Laser Technology”].

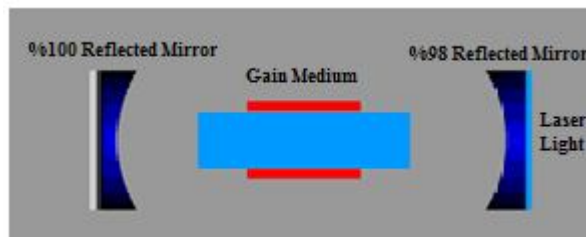

Figure 1. Typical simplified diagram of a laser

In stimulation, photons numbers increase at medium. Almost all atoms when begin to propagate photons and strengthening light get out from semi-glazed end. It is laser light. If an atom has maximum amount of energy, this atom cannot take more energy in its structure. When this type of atom clashed with same energy of light wave as a result of this atom give its all energy as a light wave. And this atom propagates same frequency and level two light wave with collides wave. In order to increase number of impact, so for gain more light, parallel two mirrors located to facing side.

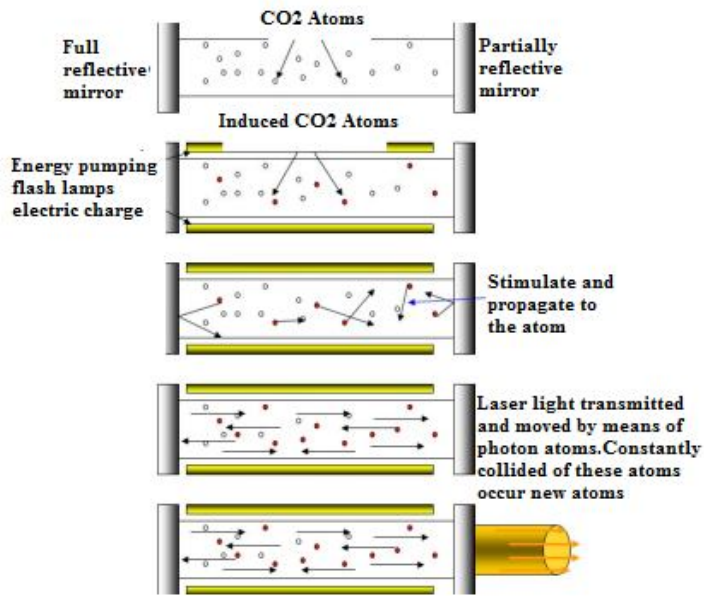

Figure 2. The first occurrence of the laser

Light wave which hit randomly with right angle to one of these mirrors, is reflected opposite mirror and after light is go and return between two mirrors. It does not get out. While light particles pass through inside that material used in making the laser, light particles encounter to energy full of atoms. And these light particles enforce these atoms in order to bring out their energy as a light. Thus, the number of atoms in glowing and amount of light can be increased constantly. It is not possible to do something with more and more concentrated light between two mirrors. Because of this reason one of these reflectors has a semi-permeable property. A part of light gets out by means of it. Laser consists of the spread of photons in the light.



Figure 3. Laser light

If excited state of an atom which has a certain wavelength along the short time interval is reacted with photon as a result of this the atom emits same phase of photon. This process is sequentially repeated, in exactly the same phase light beam is obtained. If photon is given from outside to atom in the lowest energy level, atom is stimulated from E_1 energy level to E_2 by means of gained energy. If atom left to its own state this atom gives its photon and come back again E_1 energy level. Laser is developed by Einstein works that on the basis of the principle of stimulated emission. This principle is based on the three fundamental bases. These are spontaneous radiation, absorption and stimulated emission.

Accordingly

E_1 = Low-level atomic energy

E_2 = High-level atomic energy

$E = E_2 - E_1$

E = Photon

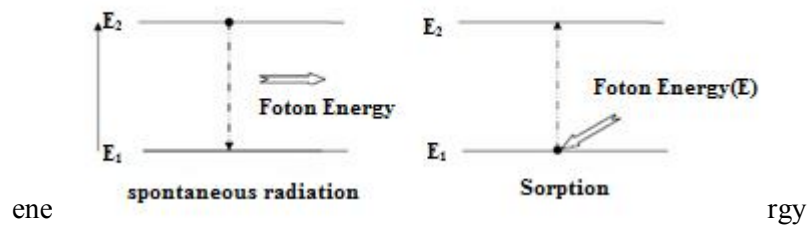

Figure 4. Spontaneously radiation and absorption

As can be seen from the figure that self-radiation event happen that high level of atom pass to low level event. And result of it light is obtained.

Absorption event is low level atom passes to high level of energy thanks to absorbed photon.

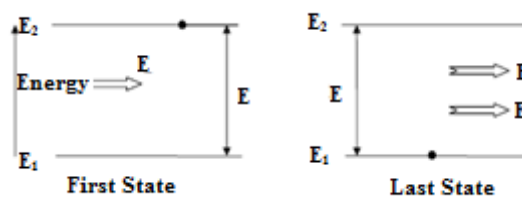

Figure 5. Stimulated Radiation

Induced emission is shown in the figure, the high level of the atom-photon is forced to reduce low-level atom. The photon energy equals to the energy difference between the two levels. As a result, two-photon moves away from the atom. Light is strengthened since two photons movement is simultaneous. In stable orbits of electrons stimulated with an energy coming from outside and ascend higher orbit. During turns again old stable event then the electrons give energy which they take beginning of stimulation. The emission process constitutes the main principle of laser. The electrons of atom's orbit can absorb or propagate the photons and they can pass higher or lower orbits.

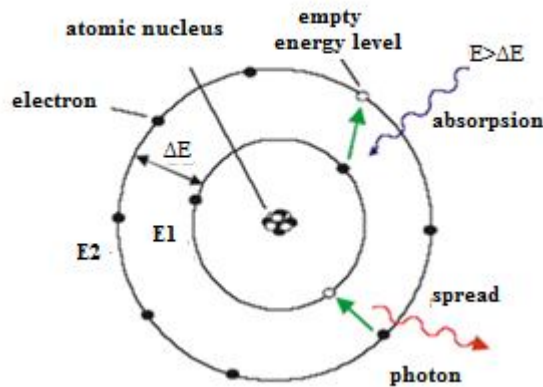

Figure 6. Bohr Atom structure

This process continues to collect same phase photons. Laser light's wave length compatible with distance of mirrors. It is called induced diffusion process at same frequency so, same wave length photon production. If this operation is performed for millions of atoms, millions of photons are emitted shape of parallel light beams from a point. These beams almost attached to each other because these beams have same frequency and same phase. The basis of the growth of the energy of the laser beam is result of millions of small sources of energy combine shape of very narrow beam side by side sequential in the same direction. Energy level falls of atom must be upgraded more atoms to alerted energy levels in order to working laser. This situation is the opposite of the normal distribution of energy levels in atoms. For this reason, the necessary condition for laser operation is called an inverted distribution. Pumping process is used for reveal inverted distribution [Svelto 1998; Paschotta 2007; <http://www.bgu.ac.il/~glevi/website/Guides/Lasers.pdf>, „Introduction to Laser Technology”].

Color	Wavelength	Frequency
violet	380–450 nm	668–789 THz
blue	450–495 nm	606–668 THz
green	495–570 nm	526–606 THz
yellow	570–590 nm	508–526 THz
orange	590–620 nm	484–508 THz
red	620–750 nm	400–484 THz

Figure 7. According to the colors of laser wavelength and frequency range

3. Classes of lasers

The active ingredient in the laser optical chamber may be solid, liquid, gas or semiconductor. Many types have laser and usually they take the name from forming laser light source name.

3.1. Solid State Lasers

The first laser is ruby laser. Ruby which has a small amount of chromium is aluminum oxide crystal. Red laser beams is emitted by chromium atoms in the crystal. Chromium atoms are optically stimulated light green and purple. This type of laser can transport million watt powers in one billionth of a second in such a short period. Laser in use today, is composed of a hard transparent crystal. Crystals are rarely available rare earth elements in small quantities. Room temperature should be reduced for the crystal process. Working frequency can adjust by means of adjusting temperature and magnetic field. The solid lasers, in general yttrium and aluminum garnet crystal is used, this is known as YAG lasers. Forming effect of laser material is embedded within a solid matrix. Neodymium is one of the rare earth elements used in the various crystals. Due to the energy level does not need more optical pumping. For this reason it is preferred.

3.2. Semiconductor Lasers

The laser made from crystals which obtained semiconductor materials. Also known as a diode laser and they are not solid. Gallium arsenic crystal may be an example for semi-conductor laser. Such as semiconductor pn diode is composed of combination of materials, pn junction surface of the material serves as ruby laser mirrors. When positive voltage given p side and negative voltage given n side at the combination of surface electrons passed from n material to p material loss energy and propagate photon. These photons cause to produce more

photons through hitting electrons. As a result, reaching sufficient level of propagation is produced photon laser beam. Semiconductor lasers are efficiency light sources. Generally their length is not bigger than a millimeter.

3.3. Gas Lasers

The first gas laser is used in the form of a mixture of noble gases helium and neon. This noble gas mixture is placed a long tube and between two spherical mirror and laser was produced. Working with helium and neon gas lasers are ionized under high tension. Helium atoms during the electrical discharge are stimulated with electrons colliding and after helium atoms are increased high-energy levels. These, their gained energy are transferred to neon atoms' equal energy levels. This energy transfer process leads to spread of photon. Laser beam can be obtained after reaching a sufficient level by means of mirrors. This kind of laser beams wave length level is 0.6 to 0.8 micron.CO2 laser emits infra-red light and used to cut hard materials. Another type of gas laser is argon laser.

3.4. Chemical Lasers

In chemical lasers, produced a gas and it is pumped way of chemical reaction. Chemical pumping is done to reveal energy at an exothermic chemical reaction. For an example; when hydrogen and fluorine elements react for occur hydrogen fluoride in inverted population laser effect comes out.

3.5. Liquid Lasers

The most used kind of liquid lasers which include Rhodamin 6G and used complex organic dyes in the form of liquid solution or suspension. With them, laser kind which can obtain between ultra-violet and infrared. Generally, pumping occurs in form of optical. A few lasers can be worked in parallel type. The most important dye lasers' feature is its wavelength can be adjusted in a wide range of field [Siegman 1986; Svelto 1998].

4. Field of lasers

Nowadays, laser used in almost every field of technology and has been the most important element. Were of using laser technology or not we use this technology in daily life. Especially lasers are used in industrial, security, communications, military and medical fields.

4.1. Industry

Laser is used for cutting metal or other materials and guiding aircraft when it is landing and departing. Laser printers are devices which used for taking high-resolution documents.



Figure 8. Wood processing made with laser

Material can be coated with melted wire with using laser beams.



a)



b)

Figure 9. Dental bridges and turbine components produced by laser polymer

Direct metal laser sintering is used by dental laboratories for formed Coping bridges. Expensive materials and quality structures for thin structures decrease manufacturing time and cost. Laser applications have been had a growing demand at repair and renovation aviation for aircraft engine. Also the aircraft engine manufacturer Rolls-Royce has participated.

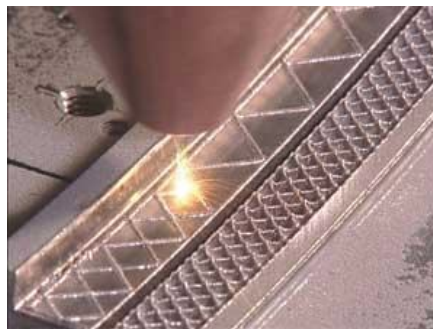

Figure 10. Thin mesh (0.3 mm) wall created with laser

4.2. Security of Way

Laser radar signals utilized in ensuring the safety of the road.

4.3. Communication

Lasers is used communicate between ground and satellite systems. Also used in fiber optic systems in communication network.

4.4. Military

In military, laser is utilized for determine target. Laser weapons are still being worked on construction of the subject.

4.5. Medicine

Lasers used in medical field are many and varied. However, these lasers are divided into two groups.

4.6. High-power laser

These lasers are used in processes such as cutting tissues and blood curdles. Lasers of these type can able to do very clean and bleeding cutting and allow eliminating diseased tissues without harming healthy tissues. These lasers' power is over the 30 W.

4.7. Low-power laser

Low-power lasers are used for stimulate and arrange to cell and tissue working. These lasers' power is 0.1mW and 0.500 mW.

In this sense the field of medicine of our time is considered high-powered lasers are powerful weapon belong to the surgeon, low-powered lasers are powerful weapon belong to the internist. Accordance to the terms which established in world literature when we say „Laser surgery” it means that high-power lasers, when we say „Laser Therapy” it is thought to treatment with low-power lasers.

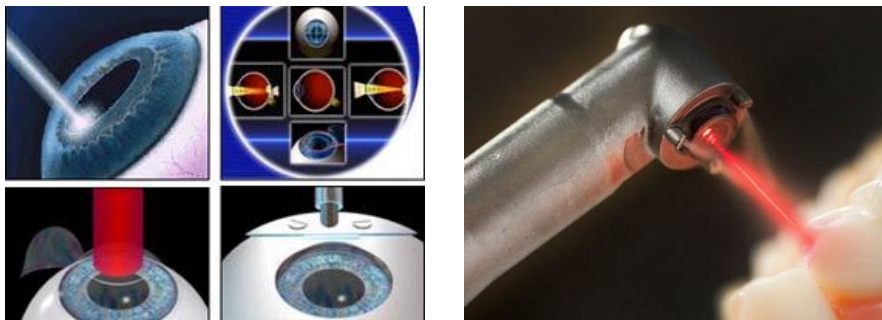

Figure 11. Laser is used in dental and eye treatment

5. Application of wireless audio transmission circuit

There was designed a mechanism that using laser to transmit the audio signal meters away. Two separate circuits designed for accomplished wireless audio transmission with laser. Transmitter can use an audio source such as a radio or mp3 [Khalifeh, Yousefi'zadeh 2008; Barros, Oikonomidis 2002].

The system works briefly as follows:

Laser circuit is connected to the headphone socket of radio. The laser in circuit converts electrical audio signal to optic signal. When audio signal amplitude is changed up and down, the current which following to laser changes in the same way. Thus the laser beam is move voice information. When laser beam is focused on receiver circuit's LDR the changes of light intensity caused changing in LDR's resistance. And variable current flows through the headphones that are connected in series. This current's waveform and audio signal's waveform are approximately same. In shortly thanks to circuit which exists away from the tens of meters user can listen transmitted desired tone or radio broadcast.

Wireless audio transmission equipment required for this study:

- Laser Pointer (1 Piece),
- LDR (1 Piece),
- Audio transformer (1 Piece),
- Mobile Radio (1 Piece),
- Headphones (1Piece),
- 100 ohm resistor (1 Piece),
- Red LED (2-Piece),
- 9-volt battery (2 pcs),
- Headphone socket (female and male jack) (1 Piece),
- Solar panel,
- Soldering gun and solder wire,
- Printed circuit board.

6. Circuit construction

The socket has right, left and chassis point. This project will be sufficient to use both ends. 15–20 cm long cut audio cable must be soldered on the right and chassis ends. So the cable which connected headphone output is prepared. Prepared this cable should connect to the low resistance audio transformer's primary ends. To make the connection correctly windings resistance should be measured with a voltmeter. As shown the winding's resistance should be low and other winding resistance should be higher than another.

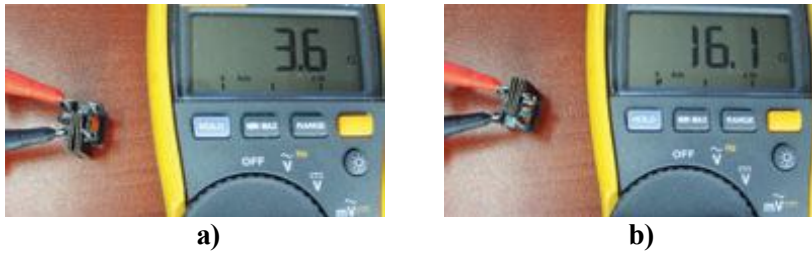

Figure 12. Application of winding test

Two LEDs in the circuit diagram soldered the secondary terminals. Then the 100 Ohm resistor soldered onto the 9V battery title. Thus the construction of the transmitter circuit is completed.

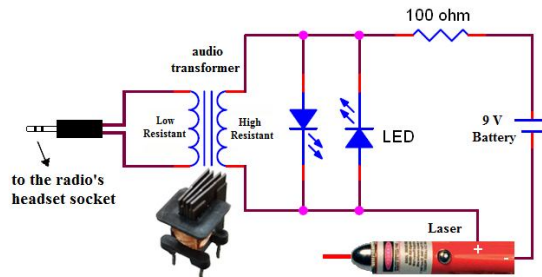

Figure 13. Transmitter Circuit

Receiver circuit is given in figure 14. It has a very simple structure. The circuit has only 9 V battery, LDR and headset.

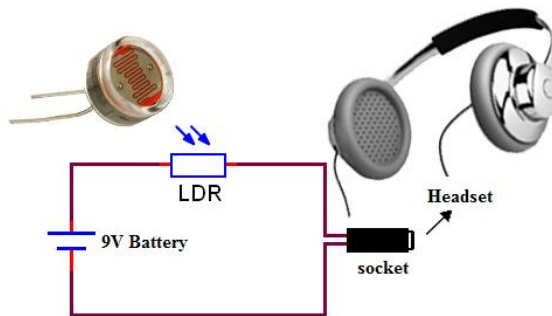

Figure 14. Receiver Circuit

Female stereo jack for headset provides the convenience of connecting circuit is a good choice to use. 15–20 cm long, cutting audio cable is connected to the left and right ends of the socket. Ground is not used. Thus audio signal reaches same level to the both sides of series connected headphones.

Laser Wireless Audio Transmission Circuit drawing at Proteus are given in Figures 15–16.

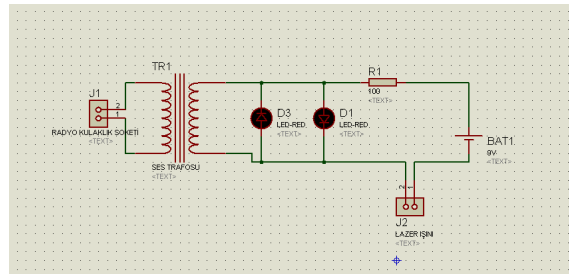

Figure 15. Proteus Drawing of Transmitter Circuit

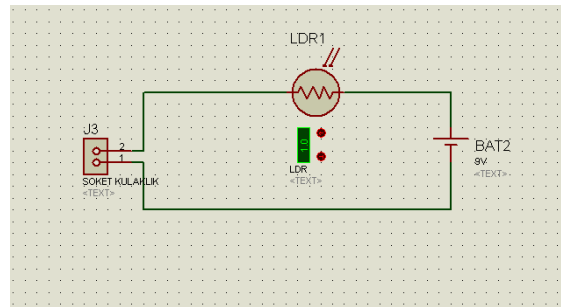

Figure 16. Proteus Drawing of Receiver Circuit

Experimental study of Laser Wireless Audio Transmission Circuit is shown in Figure 17.

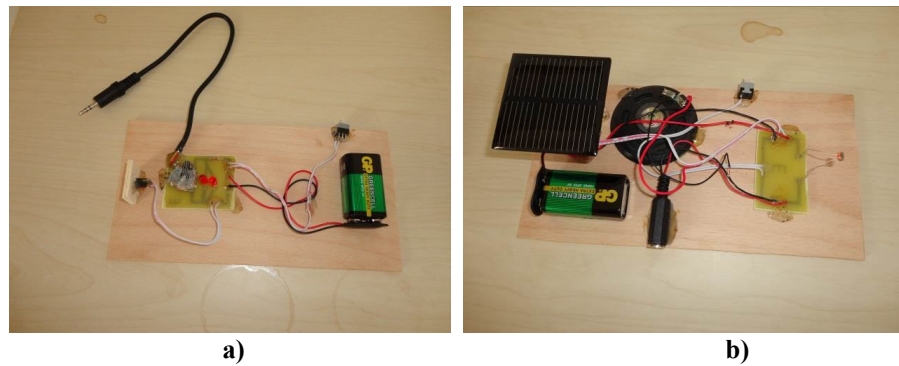

Figure 17. Experimental study of a) transmitter and, b) receiver circuit

The transmitter and receiver circuit of laser wireless audio transmission are worked properly.

7. Conclusion and recommendations

Alternative wireless audio transmission with using laser beam is current and new transmission method. This study can separate itself easily from other communication methods. Although this method not known and not used extensively. This method will light on such projects in future. Forming the basis of research laser and sound transmission circuit that one of the reason of not using commonly this laser and sound transmission circuit is used commonly 3G, Wi-Fi, wireless audio and video transmission systems. One of the reasons that there is not commonly research related this study, and it stems from lack of academic research and scientific studies. Much scientific research can be searched on this topic and it can be developed more. By means of the obtained results these circuit applications can increase obtained economic benefits and produced alternative sound transmission systems. As a result of this will be enabled the thought of contributed the country's economy. Increased the quality of used transmitter (laser) and receiver circuit elements allows that proportional sound transmission. Also it provides to transmit sound more clearly form and more away distances than before. Wireless audio transmission circuit and laser allow transmitting the sound depending on the used kind of laser until 5 km. In conclusion, this study is applied as a small circuit concept and was observed to working well. Areas of this study can be increased with the development of this study. And it can be one of the ways that transmitting sound with wireless audio transmission instead of cable voice transmission.

Literature

- Barros J., Oikonomidis I. (2002), *Wireless transmission of packet audio using multiple descriptions*, *Personal, Indoor and Mobile Radio Communications, 2002*. The 13th IEEE International Symposium on, 2452–2455, vol. 5, Sept. 2002.
- Clark P. (1981), *Overview of high energy laser device technology for military applications*, *Quantum Electronics*, IEEE Journal of, vol. 17, Issue: 12, Page(s): 2528, December 1981.
- Einstein A. (1972), *On the quantum theory of radiation* [in] *Laser Theory*, ed. F.A. Barnes, pp. 5–21, IEEE Press, New York.
- Fermann M.E. (2009), *Ultrafast Fiber Laser Technology*, *Selected Topics in Quantum Electronics*, IEEE Journal of, vol. 15, Issue: 1, Page(s): 191–206, Jan 2009.
- Hecht J. (2010), *Short history of laser development*, *Opt. Eng.* 49, 091002.
- Hermann Haken (1983), *Laser Theory*.
<http://www.bgu.ac.il/~glevi/website/Guides/Lasers.pdf>, „Introduction to Laser Technology”.
- Khalifeh A., Yousefizadeh H. (2008), *Optimal Audio Transmission over Wireless Tandem Channels*, *Data Compression Conference, 2008. DCC 2008*, 525, March 2008.
- Lamb W.E., Jr., and Retherford R.C. (1950), *Fine structure of the hydrogen atom*, part I, *Phys. Rev.* 0031-899X 79, 549–572.
- Ming W.K., Kwan S.Y. (2006), *Wireless audio transmission system*, U.S Patent, 09/905, 815.

- Paschotta R. (2007), *Field Guide to Lasers*, SPIE Press, Bellingham, WA.
- Siegman A.E. (1986), *Lasers, University Science Books*, Mill Valley, CA.
- Slusher R.E. (1999), *Laser Technology, More Things in Heaven and Earth*, Pages: 798–811.
- Svelto O. (1998), *Principles of Lasers*, Plenum Press, New York.
- Wenqi Huang, Hong Yang (2011), *Comparative study on three methods of wireless receiving of audio signal*, Artificial Intelligence, Management Science and Electronic Commerce (AIMSEC), 2nd International Conference on, Aug. 2011.
- Zhang L., Yang Y., Lai K. (2005–06), *Laser in Large-scale Integrated Circuit Application and Prospects [J:] Laser & Optronics Progress*.

Abstract

In technology, we see major innovation and improvements in our daily tools and machines. Meanly, technology is in constant race to get better than yesterday. It has been amazing upwards trend in technology over last 20 years to the level of „space time”. One of the major technology development areas are in the laser field. Although laser technology has been out there for many years, we have seen tremendous new laser applications recently. We are taking advantage of laser technology in all aspects of our life. As long as we use its precise and right parametric range, we get very valuable results. In this study, general information about lasers and laser wireless audio transmission circuit application was designed.

Key words: laser, audio transmission, wireless communication, laser technology.