

# Iron Age Metalworking at Masafi-1? A Reconsideration of the Metal Hoards Discovered in the Collective Buildings

ANNE BENOIST, AURÉLIEN HAMEL, CÉCILE LE CARLIER,  
MICHELE DEGLI ESPOSTI, JULIE GOY

**Abstract:** Excavations in a series of superimposed Iron Age II collective buildings located at Masafi (Fujairah, UAE) by the French Archaeological Mission in the UAE allowed the discovery of two deposits of copper-base metal items buried in two jars. Copper smelting played a major role in the economy and the society of the region and consistent evidence suggest that it also had a symbolic importance. A summary of the archaeometallurgical study of the items discovered at Masafi is presented here and the context of the two deposits is discussed, in order to reconstruct the nature of these two hoards and the function of the buildings.

**Keywords:** Iron Age, metallurgy, UAE archaeology, copper working

Anne Benoist, UMR5133, Archéorient CNRS, Lyon; [anne.benoist@mom.fr](mailto:anne.benoist@mom.fr);  0000-0001-5867-2617

Aurélien Hamel, Service du Patrimoine et de l'Archéologie, Département de la Vendée, Vendée; [aurelien.hamel@vendee.fr](mailto:aurelien.hamel@vendee.fr)

Cécile Le Carlier, UMR6566, CReAAH, CNRS, Rennes; [cecile.lecarlier@universite-rennes1.fr](mailto:cecile.lecarlier@universite-rennes1.fr)

Michele Degli Esposti, Institute of Mediterranean and Oriental Cultures, Polish Academy of Sciences, Warsaw; [mdegliesposti@iksio.pan.pl](mailto:mdegliesposti@iksio.pan.pl);  0000-0002-7544-0735

Julie Goy, ArScan, CNRS, Nanterre, University of Paris I, Paris; [julie.goy@lilo.org](mailto:julie.goy@lilo.org)

Masafi is a mountain oasis in the northern part of the al-Hajjar range (Emirate of Fujairah, UAE). Excavations and geo-archaeological work carried out in this region by the French Archaeological Mission to the United Arab Emirates (FAMUAE) under the successive directions of Anne Benoist and Julien Charbonnier have revealed an occupation dated to the Iron Age II period (1100–600 BC), which was organised in two clusters installed on either side of an ancient oasis: to the west, a fortified village was built on the slope of a rocky hill (Masafi-2); to the east, a complex comprising a succession of collective buildings built

and rebuilt on the same site (Masafi-1) and a sanctuary (Masafi-3) extended along the periphery of the oasis.<sup>1</sup> The material collected on the three sites as well as four <sup>14</sup>C dating obtained at Masafi-1 and 2 suggest that these three areas were contemporaneous, broadly situated between the ninth and the sixth centuries BC (**Table 1**).

Table 1. <sup>14</sup>C dating from Masafi excavations; calibration using OxCal v4.4 (Bronk Ramsey 2021); atmospheric data from Reimer *et al.* 2020

Sample Lab. no.	Area	Material	Phase / Locus	SU / sample no.	Age <sup>14</sup> C BP	Calibrated BC
Ly-15811	Masafi-2	Charcoal	2 / P.617, s.657	SU 325 / E.248	2510 ± 30	786–541
Ly-15812	Masafi-2	Charcoal	1 / P.612, s.636	SU 327 / E.216	2490 ± 30	775–486
Ly-15813	Masafi-1	Charcoal	2 / P.107, s.068	SU 037 / E.025	2555 ± 30	803–551
Ly-15814	Masafi-1	Charcoal	3 / P.016, c.057	SU 033 / E.024	2630 ± 30	888–774

During the excavations, an exceptional discovery was made at Masafi-1 in two of the collective buildings (Phases 1b and 2): two buried jars containing a large number of ingots and furnace bottoms<sup>2</sup> made of copper or copper alloy. These findings prompted a programme of archaeometallurgical studies, which was carried out by Julie Goy as part of her PhD thesis.<sup>3</sup> This paper revisits this discovery and its context based on a re-examination of the data.

## GEOLOGICAL BACKGROUND

South-east Arabia includes the current territories of the Sultanate of Oman and the United Arab Emirates. It is a roughly triangular territory, covered in the west by a dune field that marks the eastern end of the Rub al Khali and occupied in the east by the al-Hajjar mountain range, that forms an arc *c.* 700km long and 50 to 140km wide from the Musandam peninsula to the Ja'alan plain, with the highest peaks in central Oman at a height of 3,000m.

The central formation of the al-Hajjar range is composed of a massive set of metamorphic and igneous rocks and it is especially rich in various ores (copper, nickel, chromium, chromite, laterite, manganese).<sup>4</sup> Copper was mined as early as the third millennium BC<sup>5</sup> also to be exported to Mesopotamia,<sup>6</sup> a pattern that probably continued, although less intensively during the second millennium BC with the mediation of Dilmun.<sup>7</sup>

<sup>1</sup> Benoist 2010a; 2013; Benoist *et al.* 2012a; 2012b; Charbonnier, Purdue, Benoist 2017.

<sup>2</sup> This term is used to indicate the mass of solidified smelted copper/copper alloy recovered from the bottom of a furnace (from which it takes the shape) after a primary smelting operation.

<sup>3</sup> Goy 2019.

<sup>4</sup> Batchelor 1992; Michel (Ed.) 1993.

<sup>5</sup> Weisgerber 1980; 1981; Hauptmann, Weisgerber, Blackmann 1988.

<sup>6</sup> Glassner 1989; Potts 1990.

<sup>7</sup> Weeks 2003; Lehner *et al.* 2023: 1403.

Fujairah is located in the northern part of the al-Hajjar range, where the mountains are lower and the copper ore formations less extended. Local resources in copper are anyhow present and have been exploited in the past, as evidenced by the number of copper smelting sites recorded during the survey carried out within the scope of the FAMUAE.<sup>8</sup>

## IRON AGE COPPER PRODUCTION

The beginning of the Iron Age in SE Arabia (the last centuries of the second millennium BC) was marked by an expansion of oases favoured by the development of the *falaj*, a system of underground draining galleries allowing the transport of irrigation water by gravity<sup>9</sup> and by the domestication of camels, which allowed for a better circulation of products and technologies.<sup>10</sup> Iron remained marginal,<sup>11</sup> but the production and transformation of copper underwent a revival, not only intended for export but mainly to answer an expanding local demand: copper and copper alloy objects appear on numerous sites, in varied contexts and sometimes in large numbers. They are mainly weapons (arrowheads, daggers, axes), some tools (hoes, chisels, knives), vessels (bowls, long-spouted ewers), elements of adornment (massive bracelets). In addition, at cultic sites, snake figurines and miniature weapons were found.<sup>12</sup>

Copper working sites marked by slag spreads, furnaces, ore or metal fragments, unfinished objects, and anvil- and hammer-type stone tools were discovered in various parts of SE Arabia (**Fig. 1**), not only in the mountains of Oman,<sup>13</sup> but also in oasis settlements in foothill areas,<sup>14</sup> at coastal sites,<sup>15</sup> and in desert regions, away from ore areas.<sup>16</sup> The remains vary in size and nature from large industrial smelting or melting sites almost entirely devoted to metallurgy (Raki-2, 'Uqdat al-Bakrah in Oman,<sup>17</sup> Saruq al-Hadid in the Dubai desert), to smaller refining sites within a settlement area (Bayt Bin 'Ātī in the Qattārah oasis, al-'Ain). The wide distribution of metallurgic activities in SE Arabia during the Iron Age suggests an intense circulation of more or less refined raw materials from the extraction and processing areas to the workshops where objects were produced.

Attempting to detail the organisation of copper working in this region, without the help of written and administrative sources, remains a difficult exercise. Proposals were made by several scholars about the role of certain buildings in the control and redistribution

---

<sup>8</sup> Goy *et al.* 2013; 2018.

<sup>9</sup> Al Tikriti 2002; Boucharlat 2003; Charbonnier 2011.

<sup>10</sup> Magee 2014.

<sup>11</sup> Lombard 1989.

<sup>12</sup> Benoist 2010b.

<sup>13</sup> Raki-2: Yule, Weisgerber 1999.

<sup>14</sup> Bayt Bin 'Ātī: Power, Sheehan 2011.

<sup>15</sup> Tell Abraq: Weeks 1997.

<sup>16</sup> 'Uqdat al-Bakrah: Genchi, Giardino 2018; Goy *et al.* 2018; Saruq al-Hadid: Qandil 2003; Nashef 2010; Weeks *et al.* 2017; Muweilah: Magee 2003.

<sup>17</sup> Although the absence of slag and the scarcity of technical ceramics may leave doubts about actual metallurgical activities (Lehner *et al.* 2023: 1408).

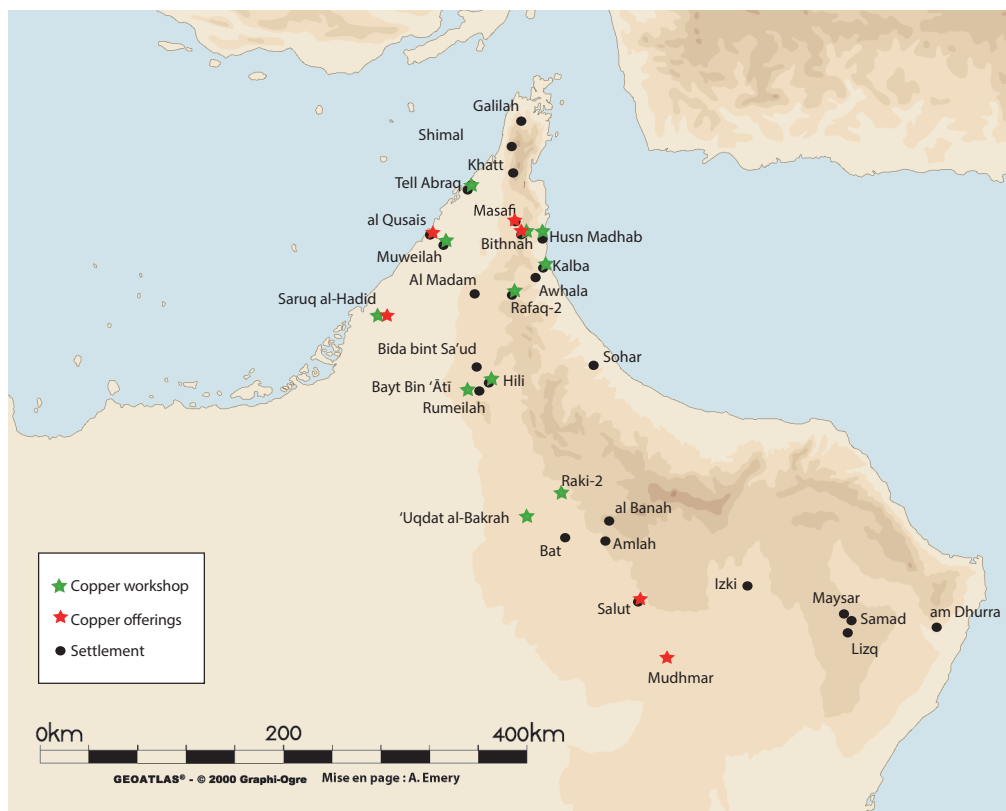

1. Map showing the location of Masafi within the Iron Age occupation in SE Arabia: sites with copper workshops and smelting evidence and sites with copper offerings (Drawing: A. Emery, A. Benoist).

of copper and other locally exploited resources on a regional scale.<sup>18</sup> These buildings include fortresses established near copper smelting sites, such as Lizq in central Oman<sup>19</sup> or Husn Madhab in the Emirate of Fujairah,<sup>20</sup> where traces of copper were found adhering to ceramic containers. They also include collective buildings comprising a reception hall with wooden posts installed on mud-brick bases. Perhaps the best example is the columned hall at Muweilah (Building II) which Peter Magee described as a building that played a central role in the control and redistribution of copper and in which copper objects were found, as well as a large number of copper fragments, which would testify to a metallurgical activity carried out on site.<sup>21</sup>

<sup>18</sup> Benoist 2010b. At the same time it needs underlining how evidence for elite control is absent at primary production sites (Lehner *et al.* 2023: 1408).

<sup>19</sup> Weisgerber 1981: 226–231.

<sup>20</sup> Corboud *et al.* 1994.

<sup>21</sup> Magee 2003. It has to be noted, however, that no pyrotechnological installation is reported from the building.

An element that complicates the question is the particular place that seems to be given to metallurgy and its products. Collective buildings with a pillared reception room were also places of representation, where rituals could occur. Copper objects and copper semi-finished products could be deposited in or around these places. This is the case of Mudhmar East<sup>22</sup> and Salut in central Oman,<sup>23</sup> and Bithnah in the Emirate of Fujairah,<sup>24</sup> where buildings comprising a meeting room possibly for gatherings and banquets are strongly connected with elements that also speak in favour of a symbolic or religious role. Among other things, one finds copper snake figurines, vessels decorated with snakes, and sometimes ingots<sup>25</sup> in contexts that can be interpreted as ritual (foundation deposits, offerings placed inside pits or on altars). At these sites, where gathering places, possible administrative functions and ritual practices are mixed, it is difficult to disentangle what is connected with the organisation of metallurgy and the control/preservation of its products and what is related to offering practices, including deposits dedicated to a deity symbolised by a snake. Masafi-1 with the small sanctuary of Masafi-3 erected nearby, is one of the places where these different aspects of collective life are intertwined.<sup>26</sup>

## THE COLLECTIVE BUILDINGS OF MASAFI-1

Excavations at Masafi-1 revealed five Iron Age building phases: 0, 1a, 1b, 2 and 3. This paper mainly focuses on Phases 1a, 1b and 2, meanwhile Phase 3 is only discussed in short.

Phase 1a saw the construction of Building 1 – the first collective building of white mud bricks (**Fig. 2**). From the beginning this building included a reception room (P.226) with a floor and walls covered with white plaster. It hosted four mud-brick bases that probably supported four wooden posts arranged in two rows in the central part of the room. A series of wooden posts also reinforced the northern, eastern, and southern walls.

The reception room was accessed from the east through a courtyard (P.1201) with a gravel floor. To the north, the central room (P.226) was linked with two small rooms (P.425, P.468). One of them (P.468) contained a large ceramic basin (MSF-2133) half-buried in the ground and filled with ashes and charcoal, interpreted as a possible structure for combustion. From the courtyard (P.1201), a long corridor (P.220), perhaps unroofed, led to a small corner room (P.219). To the west, room P.226 opened onto two parallel elongated rooms (P.100, P.101), with very smooth, whitish plastered floors. Modifications were made to the building during Phase 1b (**Fig. 3**). The two small rooms immediately to the north of the reception hall (P.226) were combined into one (P.228) and a new combustion structure was installed outside the building to the west (St.483). The former courtyard (P.1201) to the east was transformed into two very long rooms (P.119 and P.229). The former corridor in the northern part of the building (P.220) was covered during this phase of occupation.

---

<sup>22</sup> Gernez, Jean, Benoist 2017.

<sup>23</sup> Avanzini, Degli Esposti (Eds) 2018.

<sup>24</sup> Benoist (Ed.) 2013.

<sup>25</sup> Sasso 2018.

<sup>26</sup> Benoist *et al.* 2015.

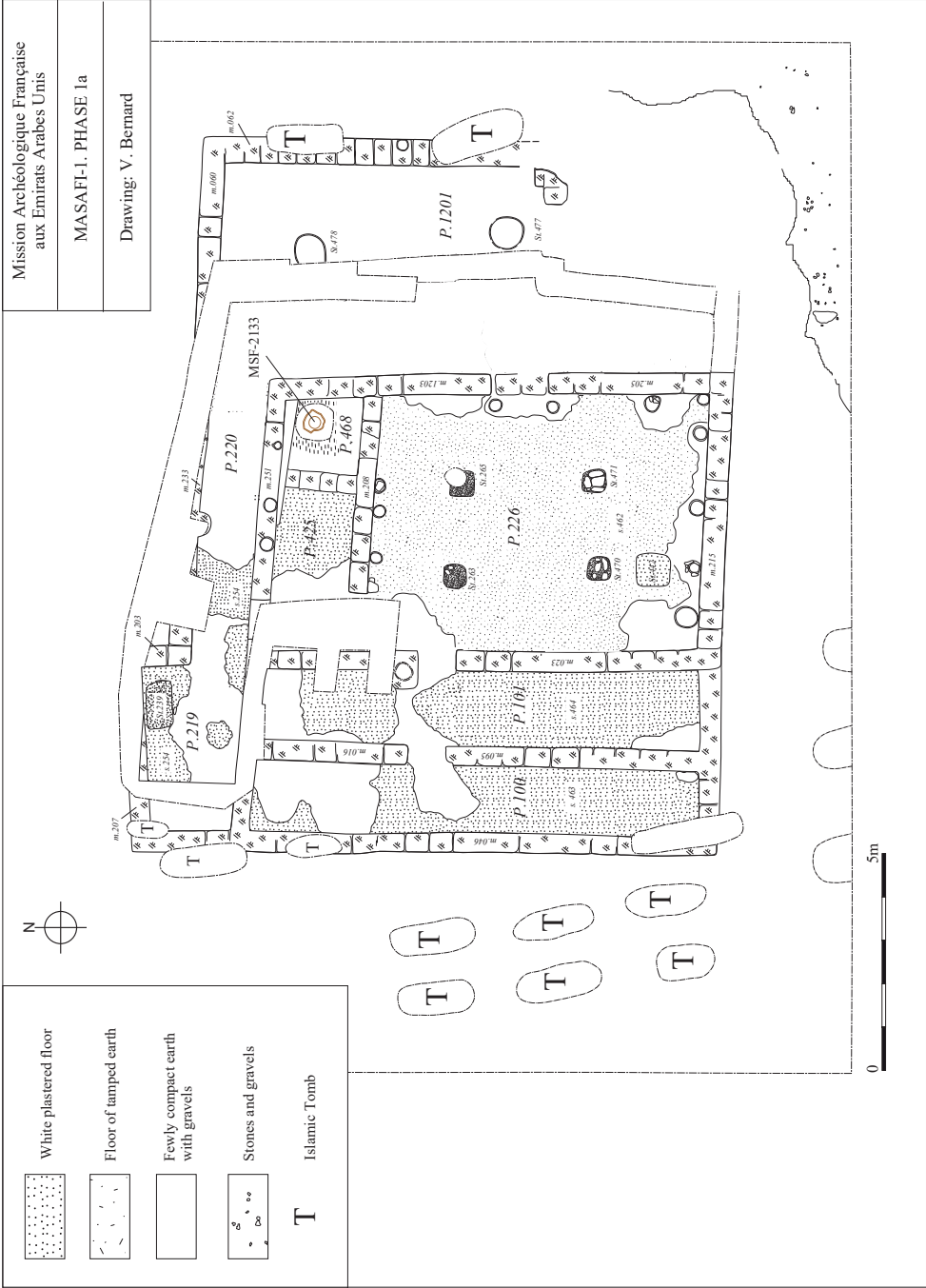

2. Masafi-1, Building 1, Phase 1a (Drawing: V. Bernard).

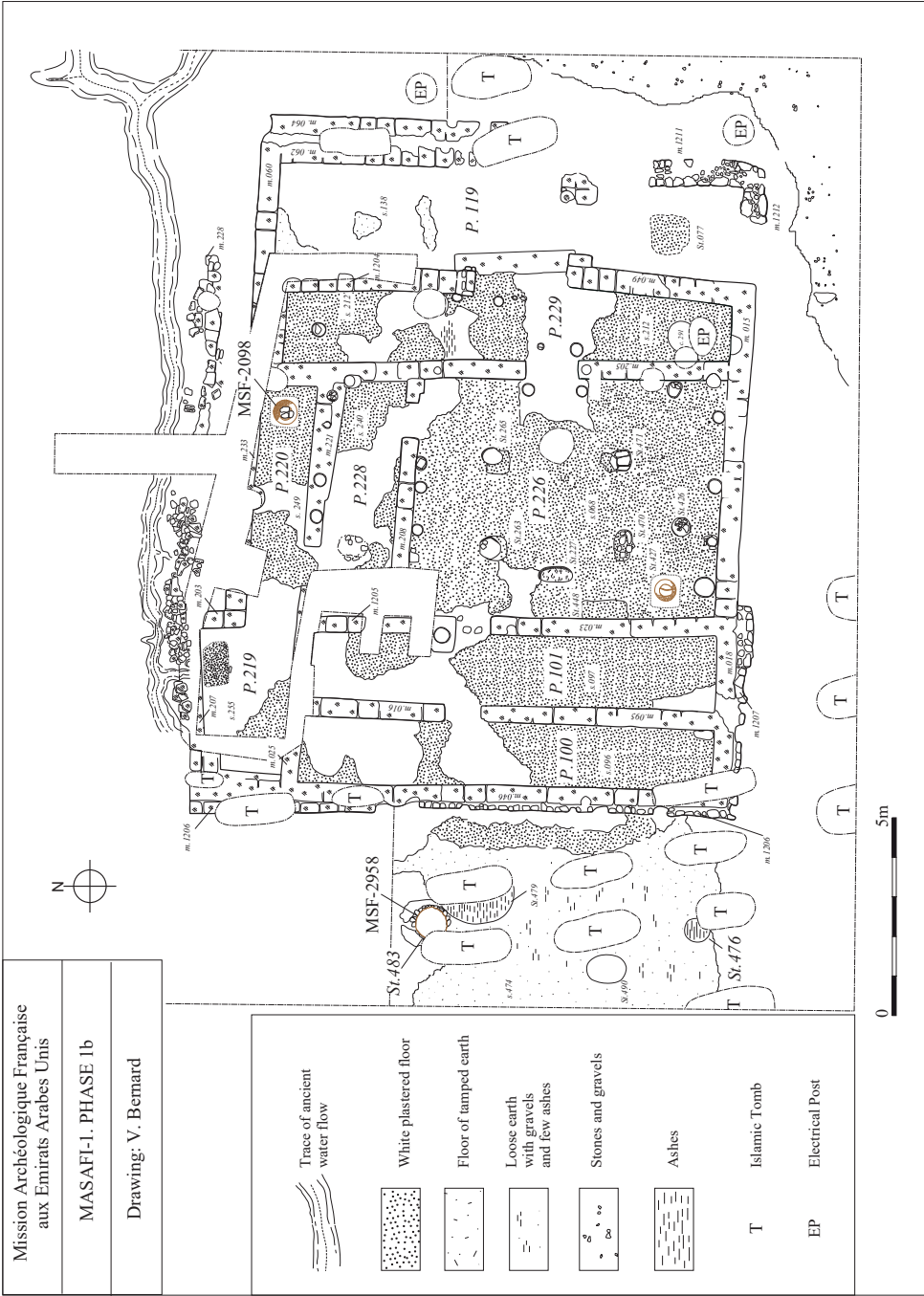

3. Masafi-1, Building 1, Phase 1b (Drawing: V. Bernard).

It was closed to the east and provided with a whitish clay floor and became accessible from the room to the south (P.228). It was in this corridor that the first jar containing ingots was buried (MSF-2098). The reception room (P.226) and the small protruding room to the north-west (P.219) remained unchanged but received a new floor covering.

During Phase 2, Building 1 was demolished and a new building (Building 2) of yellow, irregular, gravelly mudbrick was constructed above it (**Fig. 4**). A new reception hall was built (P.107). Larger than the previous hall, it extended from the north to the south of the building. It was accessed directly from the outside, through an entrance opening to the south. It was irregularly shaped, and contained seven rounded post bases – five arranged in the central part of the room, the remaining two reinforcing the northern wall. A bench extended along this wall. The reception room (P.107) contained abundant furniture, including some exceptional pieces.<sup>27</sup> In the eastern part of the room, a pit was dug in which the second jar containing ingots was buried (MSF-955). The reception room also opened to the north-west into a small corner room (P.128) built over the earlier corner room P.219. The exceptionally thick west wall of the reception room (m.061) separated it from two oblong rooms (P.033 and P.038) built above the earlier rooms P.100 and P.101. Only the northern part of these oblong rooms was preserved. Room P.038 revealed the remains of two mud brick installations forming small cubicles, each of which housed the lower part of a jar or a deep basin. Room P.033 contained fragments of at least three jars lying on the floor. Rooms P.033 and P.038 probably extended further south and may have been open to the south or south-west without direct communication with the reception room.

After a violent fire, the building was partially demolished and a third building (Phase 3, Building 3), now made of stone, was erected on the same spot (**Fig. 5**). Only the northern part was preserved. It contained a large reception room (P.017) with three rows of wooden posts set in simple holes dug into the ground. To the north-west, a new corner room (P.016) was rebuilt over the previous one. To the west of the reception room and to the south of this corner room, two small niches opened to the west (P.014 and P.015).

## THE METAL HOARDS IN THE BURIED JARS AT MASAFI-1

A total of 181 individual metal masses were inventoried from Masafi-1. They were mainly distributed in the two above-mentioned jars buried in two pits through the floor of Buildings 1 and 2.

Jar MSF-2098, buried at the eastern end of room P.220, in the northern part of Building 1 (Phase 1b), contained 139 metal masses. These include 38 complete ingots, 31 fragments of ingots and 70 irregular-shape metal fragments, which have been interpreted as furnace bottoms.<sup>28</sup> Altogether, these metal masses weighed *c.* 120kg.

The jar is a short-necked storage one of local or regional production with a thickened lip decorated with geometric incised decorations common in the region (**Fig. 6**). Buried

---

<sup>27</sup> E.g. Benoist *et al.* 2012a: Fig. 7.

<sup>28</sup> See footnote 2 above.



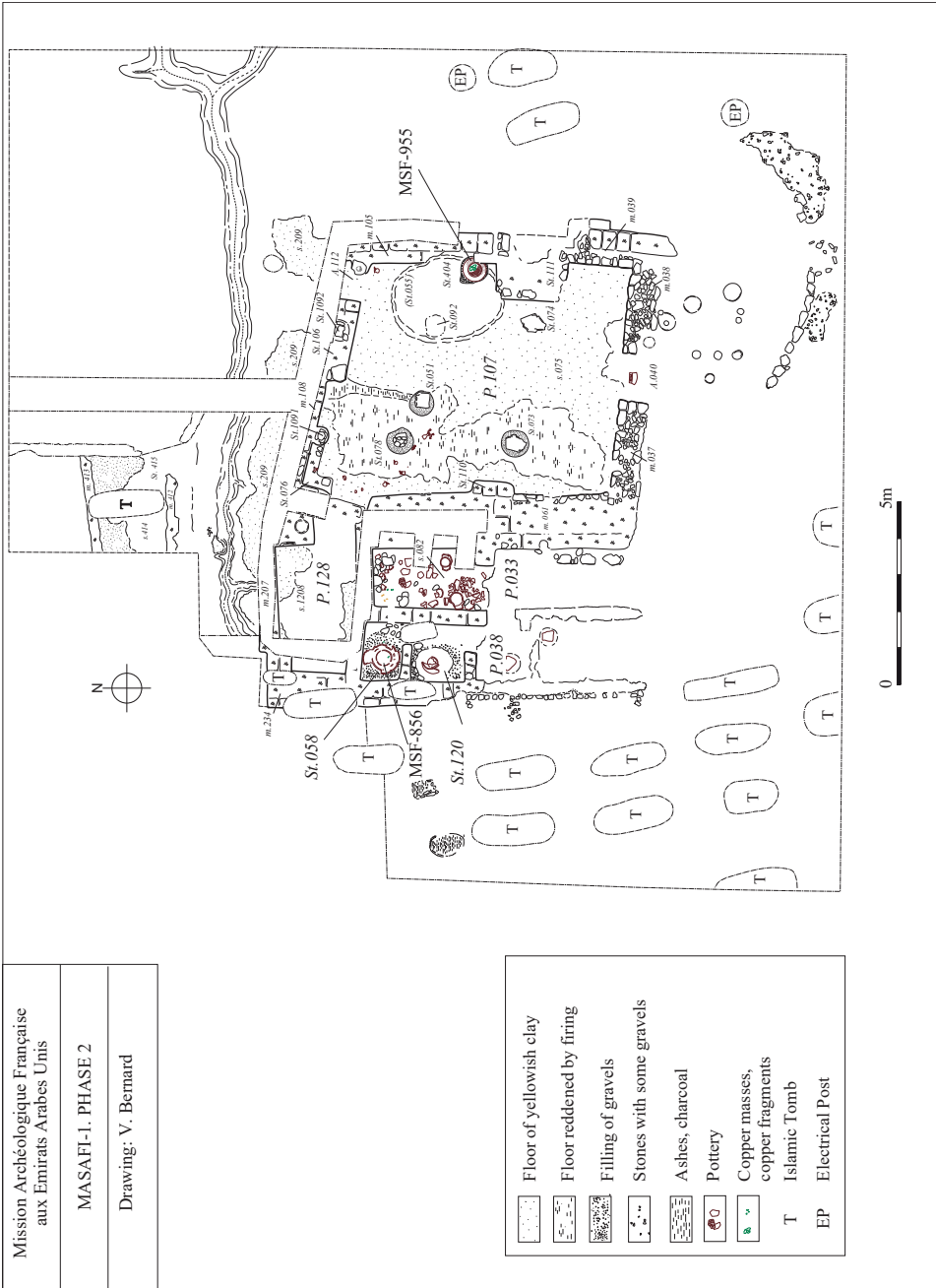

4. Masafi-1, Building 2, Phase 2 (Drawing: V. Bernard).

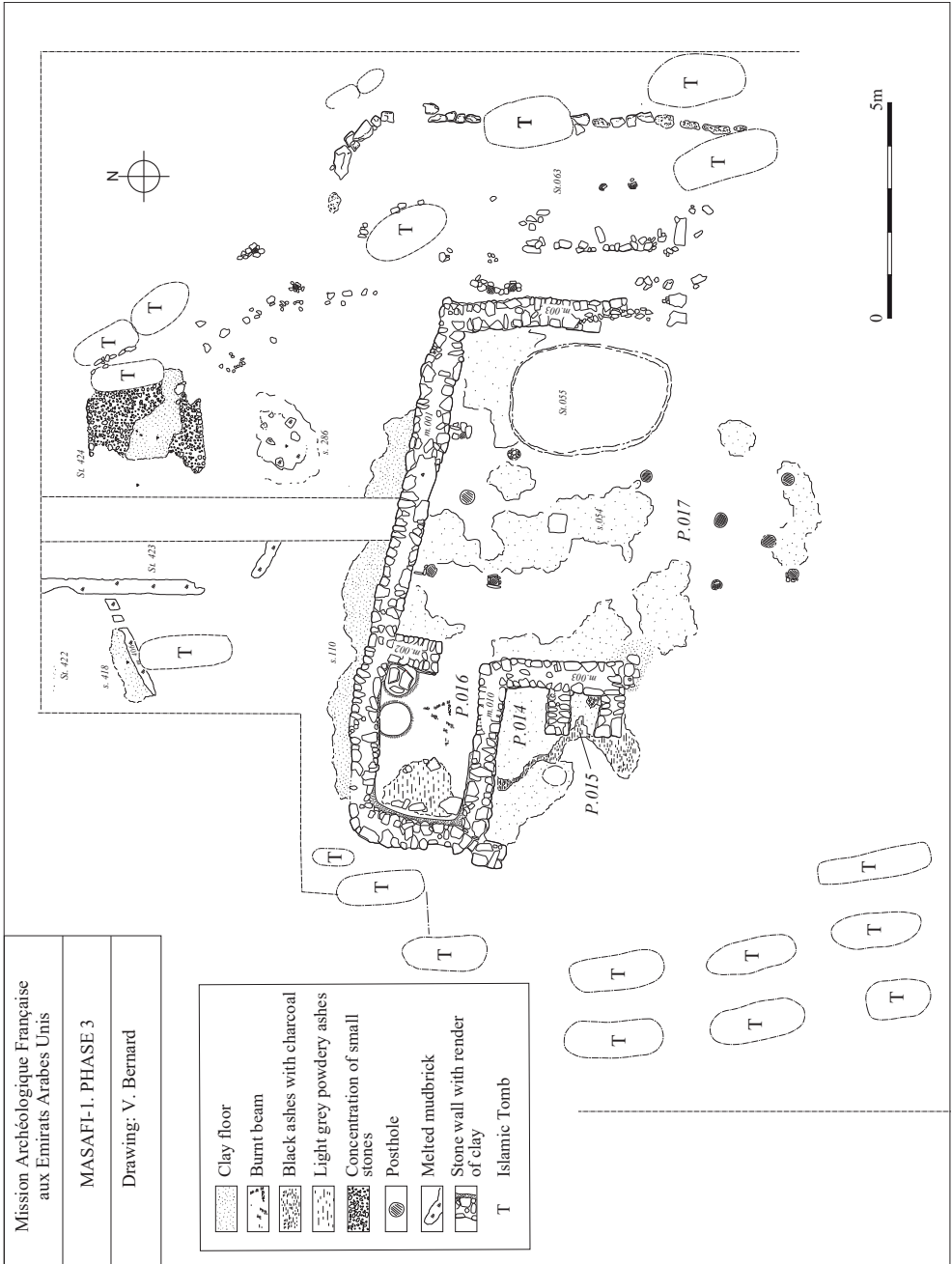

5. Masafi-1, Building 3, Phase 3 (Drawing: V. Bernard).

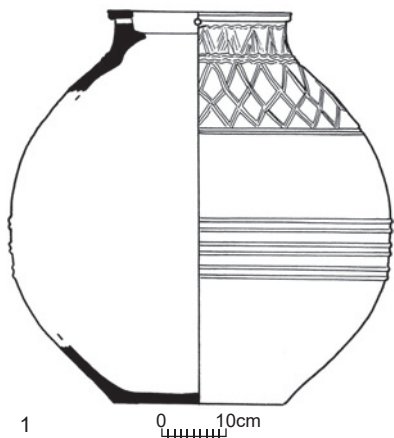

6. Masafi-1, Phase 1b, jar MSF-2098: 1. drawing; 2–3. the jar *in situ* at the moment of discovery and still sealed by its cover; 4. the jar showing copper traces on its surface; 5. view of its inside immediately after opening, showing the presence of copper masses; 6. a selection of copper masses found inside the jar (Phot. A. Hamel; drawing: V. Bernard).

in an 80cm-deep pit, its wall was partially encrusted with copper oxide and rust, perhaps due to strong heating at the time of the fire in Building 2 or perhaps due to episodes of humidity during violent runoffs. Traces of a major runoff were, in fact, identified north of Building 1's ruins (**Fig. 3**). The jar was closed by a plug of raw earth and held in place by two flat stones. It was further covered and sealed by a bench belonging to Phase 2 (St.106).

The second jar, MSF-955, contained 24 furnace bottoms and 18 ingots – complete or fragments, weighing altogether a bit less than 40kg. It is an undecorated neckless jar with a folded rim of a type also very common during the Iron Age (**Fig. 7**). The jar was buried in a square pit dug into the ground in the eastern part of the reception room (P.107) of Building 2 (Phase 2). It was disturbed at the top by a pit for the installation of a late Islamic dwelling; its rim was broken and some ingots were scattered around it, in the pit and on the floor of the Islamic dwelling.

All the copper and copper alloy items from Masafi (139 from jar MSF-2098 and 42 ones from jar MSF-955, to which can be added a few more metal masses, small fragments, and finished objects from other contexts at Masafi-1) were studied by Julie Goy.<sup>29</sup> The ingots are mainly of discoidal shape, with two flat faces (**Fig. 8:1, 2**). The underside of the ingots is flat but slightly irregular with rounded small stones and gravel impressions that suggest the metal was poured into a hole in the ground which served as a mould. The edge of the ingots is vertical. The upper surface is often smooth, with some vacuoles, and sometimes with a slight rib around the top that may have formed when the metal was too abundant and spilled over. The sizes and weights of the ingots vary, without any identifiable cluster.<sup>30</sup> The smaller ones are 6.8–8.0cm in diameter and 2.2–3.7cm thick. They weigh between 450 and 740 grams. The larger ones range from 12.5 to 16.5cm in diameter and between 2.7 to 5.6cm in thickness and weight between 1.8–3.3kg.<sup>31</sup> Other types of ingots appear in small quantities. Five are circular plano-convex ingots, with a flat upper surface, a few porosities, and a convex, relatively regular lower surface. This shape, which is reminiscent of the Bronze Age ingots found in SE Arabia, is also found at the Iron Age site of Salut and at Saruq al-Hadid.<sup>32</sup> Two other ingots have a plano-convex, oval shape.

Copper or copper alloy items from Masafi-1 include a large quantity of irregular-shape furnace bottoms stored in the two jars alongside with the ingots (**Fig. 8:3, 4**), a few fragments resulting from accidental spillage of molten metal from the furnace or crucible, and some undetermined metal fragments. These were partly found inside the two jars but also come from other contexts of Phase 2. A half complete rectangular ingot (m.010) comes from room P.033, Phase 2; the blade of a knife (m.009) was collected in a pit dug in room P.100, Phase 1b; the fragment of a bowl (m.002) comes from room P.017, Phase 3 (**Fig. 9:1–3**).

---

<sup>29</sup> Goy 2019.

<sup>30</sup> Goy 2019: 227.

<sup>31</sup> Goy 2019: 227–228.

<sup>32</sup> Sasso 2018: 311–312, cat. nos 133–148, Pls 87–88; Weeks *et al.* 2017: 44–46, Fig. 20.

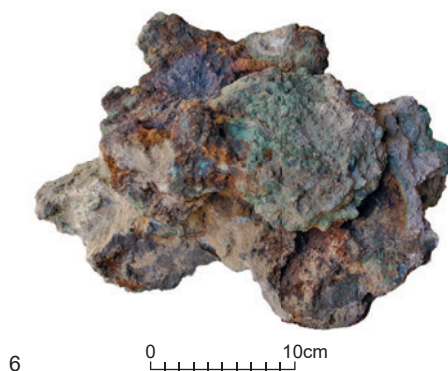
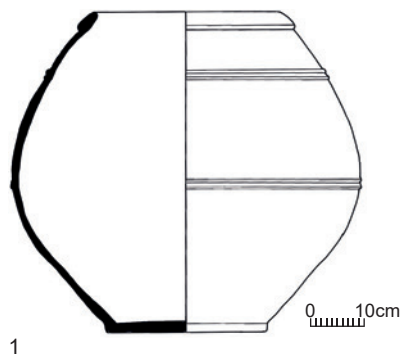

7. Masafi-1, Phase 2, jar MSF-955: 1. drawing; 2-3. the jar *in situ*, still buried in the floor of room P.107; 4. the jar after recovering it; 5. the jar *in situ* after filling removal; 6. a selection of copper masses found inside the jar (Phot. A. Hamel; drawing: V. Bernard).

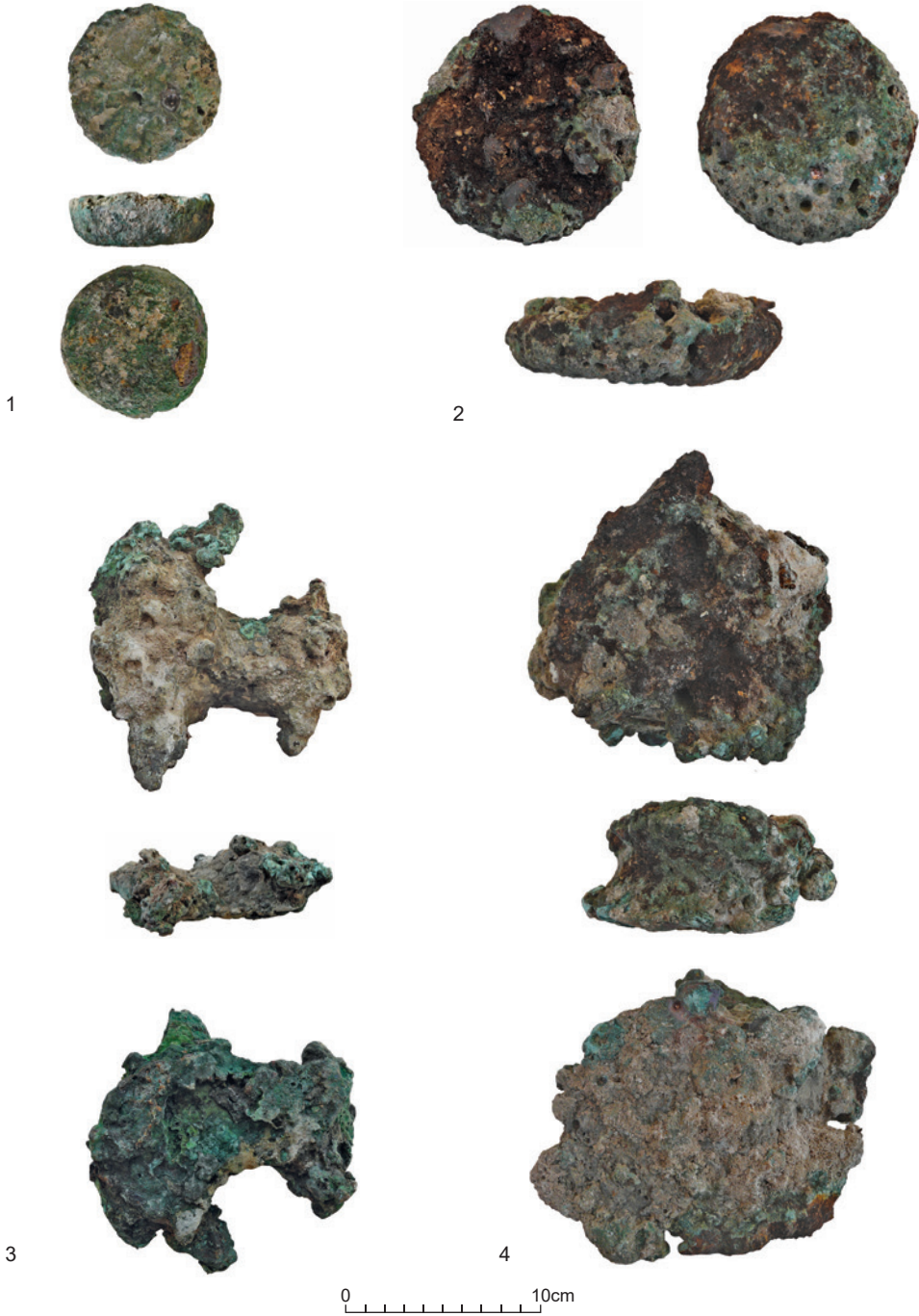

8. Ingots and furnace bottoms from Masafi-1: 1. sample 156-30, ingot from jar MSF-2098; 2. sample 22-014, ingot from jar MSF-955; 3. sample 156-55, furnace bottom from jar MSF-2098; 4. sample 22-002, furnace bottom from jar MSF-955 (Phot. J. Goy).

## ANALYTICAL PROGRAMMES PERFORMED ON MASAFI DEPOSITS

Several types of analyses were carried out on a selection of ingots and furnace bottoms from Masafi-1.<sup>33</sup> The first set of analyses combined X-ray fluorescence<sup>34</sup> and Inductively Coupled Plasma – Atomic Emission Spectrometry (ICP-AES),<sup>35</sup> the results of which have mostly been published.<sup>36</sup> Additional analyses by Goy combined elemental analyses by ICP-AES and X-ray fluorescence performed with a portable XRF device (p-XRF).<sup>37</sup>

Analyses of ingots and furnace bottoms from jars MSF-2098 and MSF-955 were compared with those of other metallurgical by-products and waste (copper slag, copper prills embedded in the slag, copper scraps) and to a few copper or copper-base objects from Masafi and 30 other sites of various types (smelting sites, workshops, settlements and graves) in SE Arabia,<sup>38</sup> in order to achieve a glimpse of ancient SE Arabian metallurgy and place the copper-base items from Masafi-1 within the metallurgical process leading from smelting to the finished object. The knife<sup>39</sup> and the bowl mentioned above<sup>40</sup> found at Masafi-1, and four snake figurines<sup>41</sup> and one spear point<sup>42</sup> from the nearby sanctuary of Masafi-3, were among the investigated objects (**Fig. 9**).

Ingots and furnace bottoms from Masafi-1 appeared to be mainly made of red copper or copper-alloy, but a few examples were of a white silvery colour, suggesting a different composition. The homogeneity of several ingots was thus verified by sampling several spots on the same object. A few examples were transversally cut in two. All ingots and furnace bottoms tested in this way are homogenous in themselves. The varying compositions between the different ingots or furnace bottoms are, therefore, due to variations in the smelting process from one item to the other and not to inhomogeneity within a single item.

The ingots found in the jars are primarily unalloyed (which means that they do not result from the voluntary mixing of several metals), although the copper content is ranging

<sup>33</sup> The analysed corpus from Masafi-1 includes 40 ingots, 34 furnace bottoms, 5 fragments resulting from a flow of metal outside the furnace and 5 undetermined fragments (Goy 2019).

<sup>34</sup> Analysis carried out by Gaffar Attaelmanan at the UAE National X-Ray Fluorescence Laboratory in the University of Sharjah.

<sup>35</sup> Analysis carried out at the laboratory Archéosciences in Rennes.

<sup>36</sup> Goy *et al.* 2013; 2018; Benoist *et al.* 2015.

<sup>37</sup> Goy 2019. The analyses were carried out at the laboratory Archéosciences in Rennes and at the Laboratory Geosciences Océan in Brest.

<sup>38</sup> Some are dated to the Iron Age, others to the Bronze Age, the pre-Islamic period or the Islamic period, still others are undated (see full list in Goy 2019: 71–283). Polished sections of 364 pieces of copper-base slag were studied with a metallographic microscope and 19 with SEM-EDS at the Centre de Microscopie Électronique à Balayage in Rennes. All the 364 slag samples were also analysed by p-XRF (Goy 2019: 284–350). 199 copper-base items from the Iron Age sites of Masafi, Kalba-4, Fashgah-1 and 2, Wa'ab, 'Uqdat al-Bakrah and Mudhmar were analysed by ICP-AES, a part of which also analysed by p-XRF for comparisons (Goy 2019: 352–420).

<sup>39</sup> m.009 (Goy 2019: sample 214).

<sup>40</sup> m.002 (Goy 2019: sample 213).

<sup>41</sup> Three moulded snakes: m.016 (Goy 2019: sample 217), m.056 (Goy 2019: sample 150), and m.044 (Goy 2019: sample 24), all from Masafi-3, layer 2. One hammered snake, m.060 (Goy 2019: sample 251), from Masafi-3, layer 1.

<sup>42</sup> m.015, from Masafi-3, layer 2.

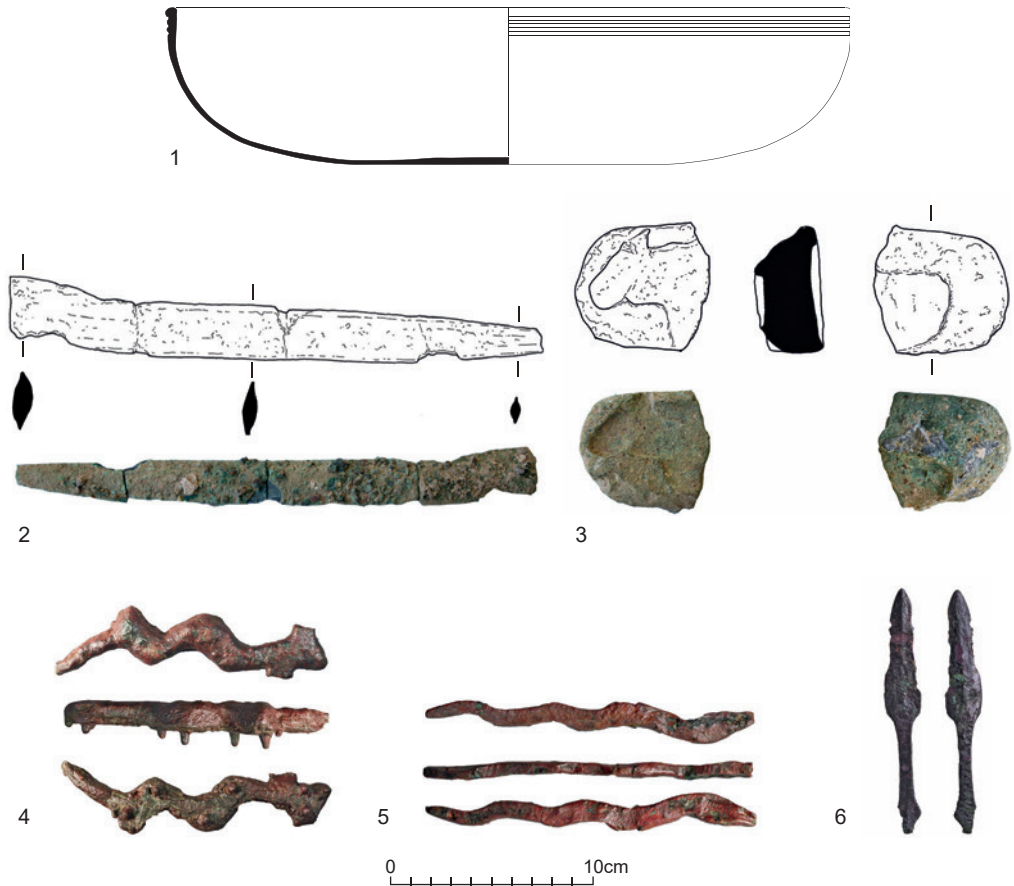

9. Copper and copper alloy objects from Masafi-1 and Masafi-3 submitted to analysis: 1. bowl m.002 from Masafi-1, Phase 3; 2. knife m.009 from Masafi-1, Phase 1b; 3. fragment of rectangular copper ingot m.010 from Masafi-1, Phase 2; 4. moulded copper snake figurine m.016 from Masafi-3; 5. hammered copper snake figurine m.060 from Masafi-3; 6. spear-head m.015 from Masafi-3 (Phot. B. Armbruster, A. Hamel; drawing: V. Bernard).

from 58% to 99%. Two of the ingots have a different composition, one with a 57% nickel content and the other with 20% lead and 18% arsenic content.<sup>43</sup>

No ingot nor furnace bottom is made of bronze, with tin content always very low (0.07% max). Iron is, conversely, often present in widely varying amounts (<5 to >30%), suggesting the use of iron-rich flux to facilitate slag removal during reduction, although the use of ores with high iron content cannot be dismissed. Arsenic is also usually present, most often in low quantities, with few exceptions. The same applies to nickel, with the exception of the ingot mentioned above, the composition of which calls for further investigation.<sup>44</sup>

<sup>43</sup> Goy 2019: 378.

<sup>44</sup> Benoist *et al.* 2015; Goy *et al.* 2018.



The finished objects found at Masafi-1 and Masafi-3 reveal a much higher and more homogeneous copper content, around 95–98%. Only the knife fragment m.009 has a tin content of 15%. The finished objects deposited in the Masafi-3 shrine are all of nearly pure copper (98–99%).

These results show that the ingots and furnace bottoms are made of a raw material which needed to be re-smelted and refined – possibly repeatedly – before finished objects could be produced.<sup>45</sup> Their somewhat disparate character (variations in size, composition, and associations between ingots and furnace bottoms of various shapes) suggest they came from different smelting workshops or the recipes varied in the same workshop from one smelting operation to another. It is not excluded that they represent successive stages in the refining process of the metal.

Initially Goy suggested that furnace bottoms and ingots could reflect two distinct stages of the melting process: furnace bottoms an earlier one, ingots a subsequent one.<sup>46</sup> However, further analysis of a larger sample showed that this was not the case and there is no consistent improvement in the purity of metal from furnace bottoms to ingots. Why, then, produce ingots? According to Goy, ingots, regardless of their compositional randomness, could have provided a better calibration in terms of size and weight, which could in turn facilitate exchange, while furnace bottoms were more likely used for local metalworking.<sup>47</sup> The copper/copper alloy objects (snakes, miniature daggers, spearheads and arrowheads) found in the nearby shrine were studied by Barbara Armbruster who highlighted different manufacture techniques: lost wax casting, hammering and folding metal sheets, cutting and shaping from thicker metal sheets. Some objects were incised with a point or a punch. It is not known where these objects were shaped, and how they might relate to the masses of raw or refined metal found at Masafi-1.<sup>48</sup> According to Armbruster, these techniques could have been used in a workshop of modest size with relatively limited tools. What traces could such a workshop have left behind? Can we highlight the presence, even occasional, of coppersmiths in the buildings of Masafi-1?

## COMBUSTION STRUCTURES AND ASH LEVELS AT MASAFI-1

In addition to the buried jars mentioned above, one or more combustion structures installed in pits and storage devices consisting of jars set into cubicles were found in the different levels of Masafi-1.

In Phase 1a (**Fig. 2**) such a feature was located in a small room P.468 measuring 1.70 x 1.40m, to the north of the reception room. It was accessed from the west through room P.425. Room P.468 did not have a white plastered floor like the others, but a simple, slightly gravelly and compacted earthen floor. It was covered with a light grey, loose,

---

<sup>45</sup> Goy 2019: 387–389.

<sup>46</sup> Goy 2019: 387–388.

<sup>47</sup> Goy 2019: 387.

<sup>48</sup> Benoist *et al.* 2015.

slightly gravelly ashy layer. A pit 0.85m in diameter and 0.60m deep was dug inside the room to host a deep basin made in common ware (MSF-2133, **Fig. 10:1–2, 4**). It was filled with a loose deposit of ash and gravel, quite similar to the one covering the surrounding floor. The walls of the basin were slightly blackened by fire. The rim was broken in places and fragments of the basin were missing. No copper-base fragments were found in room P.468, nor were any animal bone fragments and no date stones or seeds which could be expected from a domestic oven. However, charcoal was abundant.

In Phase 1b the pit and the basin were covered by a new floor and rooms P.425 and P.468 were transformed into one (P.228, see **Fig. 3** above). It was then that jar MSF-2098 and its ingots were buried in a pit dug through the floor of the elongated room further north (P.220). A fragment of basin MSF-2133 to which three copper ingots were still stuck was found within the ingots and furnace bottoms (**Fig. 10:3, 6**). This fragment indicates the possibility of a relation between basin MSF-2133 and copper metallurgy, as well as between the possible smelting of copper masses inside the basin during Phase 1a and the later burying of jar MSF-2098 during Phase 1b.

In Phase 1b a combustion structure was also found. It was located in a pit (St.483) dug into the ground west of the building (**Fig. 3**). Here as well, a fairly large basin (MSF-2958, 80cm in diameter) was set into the pit. During the first phase of use, it was gradually filled with ashy sediment and charcoal. In a second phase, the edge was raised with the addition of two layers of stones. The pit filled up again with ashes and charcoal until the content overflowed around it (**Fig. 11**). Above the pit, a grey-white indurated ash layer was finally deposited.

Around this installation, the level of occupation associated with Phase 1b consists of a wide loose, powdery and ashy layer with abundant charcoals sometimes interspersed with clay lenses, in which a few shallow pits were dug (St.476, St.479, St.490; **Figs 3, 11**), all filled with ashes mixed with silt or small reddened stones. As in the previous level, no copper-base fragments were collected. However, a small number of bones and three shells were found.

During Phase 2, two small and square cubicles were built inside room P.038 in the western part of Building 2 (**Fig. 4**; St.058, St.120). In the northern one (St.058), an almost complete jar (MSF-856) was set in a loose gravelly sediment (**Fig. 12:1–3**). It contained a fill of gravel, ash and some charcoal. Small copper-base fragments were found at the bottom of the jar (**Fig. 12:4**). Associated with this jar was a vessel with a bridged spout decorated with painted wavy lines. The southern cubicle (St.120) yielded the bottom of a second jar (**Fig. 13:2**) wedged with fragments of mud brick and another bridge-spouted vessel with a snake decoration in relief. No copper-base fragments were found inside this second jar but small ones were scattered on the ground in rooms P.033 and P.038 (**Fig. 13:5**). Animal bones and shells were also found in this area.<sup>49</sup>

Three other jars, one of which was complete, were found broken on the floor of the adjacent room P.033 (**Fig. 4**). The floor in this room, made of yellowish clay, also yielded

---

<sup>49</sup> Decruyenaere *et al.* 2022.

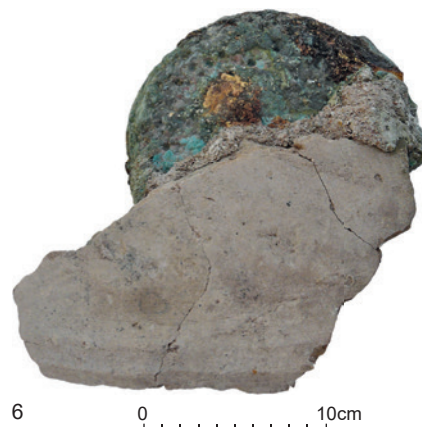
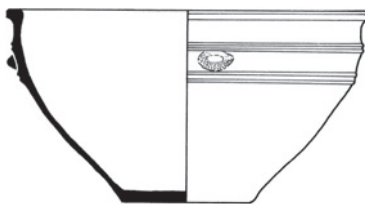

10. Masafi-1, Phase 1a, the pit with basin MSF-2133 half-buried inside, possibly a first combustion structure: 1, 2, 5. the pit in course of excavation with the basin *in situ*; 3, 6. sample 156-44 comprising three ingots stuck on potsherds belong to basin MSF-2133, found inside jar MSF-2098, in Phase 1b; 4. drawing of the basin (Phot. A. Hamel, C. Le Carlier; drawing: V. Bernard).

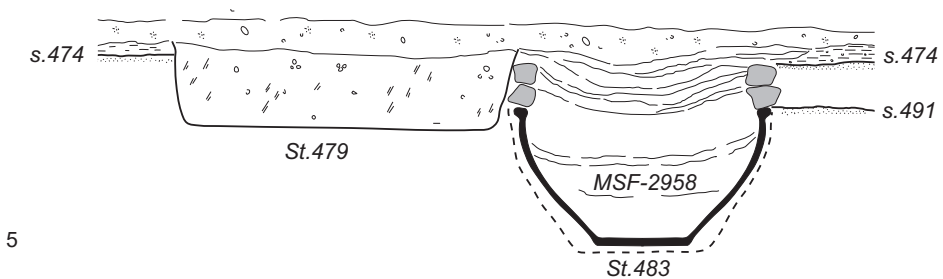

11. Masafi-1, Phase 1b, ashy layer west of Building 1, with combustion structure St.483 including basin MSF-2958 and pit St.479 next to it: 1. general view of the ashy layer; 2–4. detailed views of St.483 during excavation; 5. a schematic section of St.483 (Phot. and drawing: A. Hamel).

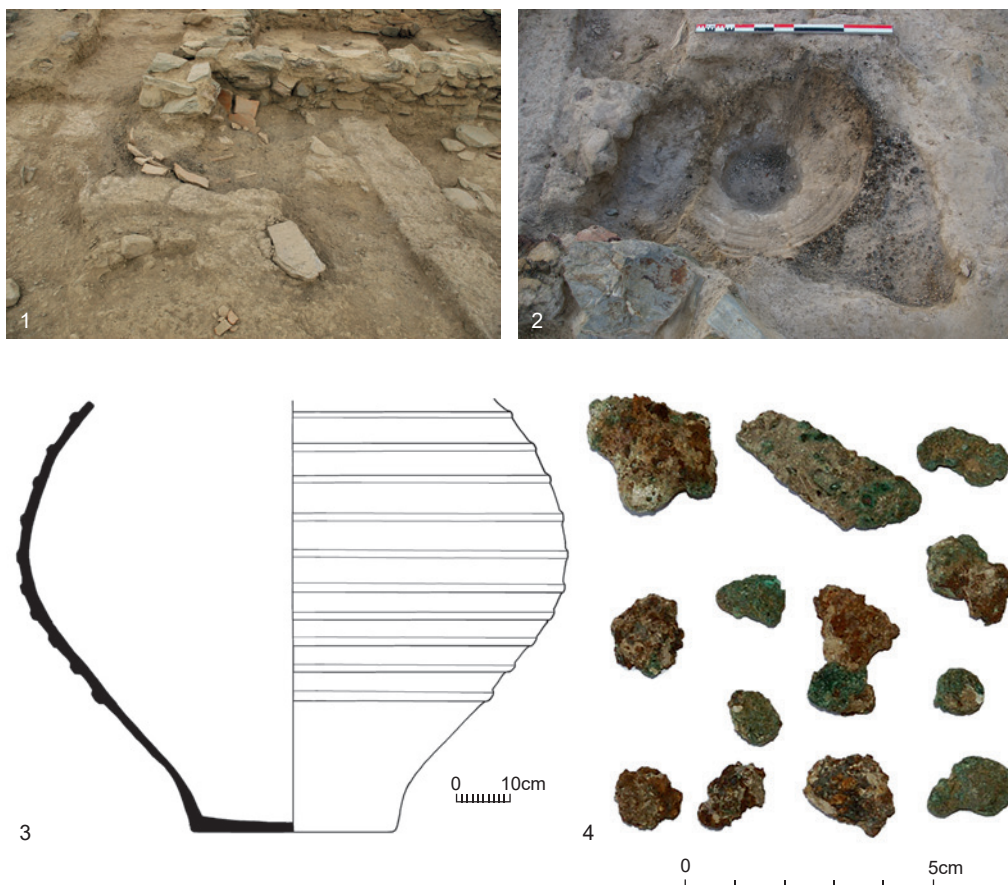

12. Masafi-1, Phase 2, Building 2, cubicle St.058 with jar MSF-856: 1–2. cubicle during excavation with fragments of jar MSF-856; 3. drawing of jar MSF-856; 4. sample of copper fragments collected inside the jar (Phot. A. Hamel; drawing: V. Bernard).

a few bones, numerous charcoal fragments, small scattered fragments of copper/copper alloy (**Fig. 13:4**), and the fragment of a plano-convex copper ingot (**Fig. 9:3**).

These small scattered copper-base fragments would suggest copper-working on site. But while an activity involving the action of fire seems obvious in the installations of Building 1, Phase 1a and 1b described above (where no copper was found), the entire western half of Building 2, including the western half of the reception room, bore the traces of a violent fire (rubefaction of floors, ashy and charred lenses, burnt objects). We do not know whether the cubicles containing the jars were simple storage places or whether they may have housed combustion structures. One element that could speak in favour of a heating activity in this part of the building could be the thickness of the wall that separated it from the reception room, which is twice as thick as the other walls of the building. This argument, however,

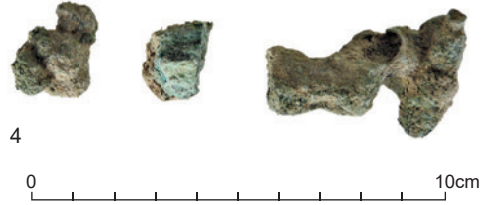

13. Masafi-1, Phase 2, Building 2, rooms P.038 and P.033: 1. general view of rooms P.033 and P.038 with cubicle St.058 in the background, before the discovery of cubicle St.120; 2. cubicle St.120 in course of excavation; 3. detail of a jar bottom in room P.033; 4. copper fragments from room P.033; 5. copper fragments from room P.038 (Phot. A. Hamel, C. Le Carlier, J. Goy).

is weak in the absence of additional evidence, and the possibility of a second storey in this part of the building cannot be dismissed.<sup>50</sup>

The combustion structure St.483 and overlaying layer of indurated ash from Phase 1b were covered by badly preserved remains from Phase 2. Two small pits filled with charcoal and ashes were dug in the immediate vicinity of structure St.483. This area could have maintained the same function from Phase 1b to 2. The remains of the subsequent Phase 3 hardly extended into this area, being limited to a layer of stones and earth with collapsed mud bricks fallen along the walls. A few copper-base fragments were found in the same area just below the surface.

<sup>50</sup> Actually no second storey have been seriously considered by archaeologists for this kind of Iron Age collective buildings encountered on several sites. A fully preserved staircase has been found in Building G at Rumeilah but the hypothesis of a possible second storey in this building was not defended by the excavators, and it might just have led to a flat rooftop (Boucharlat, Lombard 2001: 217, Fig. 3).

Is it possible to envisage metal working in this sector in a way that would make the buildings comparable with the suggestion made for Building II at Muweilah? Evidence is scarce. The most convincing indication would be the sherd belonging to a basin part of a combustion structure in Room P.468 in Phase 1a, which might suggest a link between the combustion structure and copper metallurgy. However, the sherd was recovered and placed inside a jar with ingots buried during Phase 1b, while no obvious trace of copper was found inside the combustion structure from Phase 1a.

In Phases 1b and 2, evidence for metallurgy is limited to a combustion structure outside the building, with a high quantity of ash and charcoal around it but no copper-base fragments, and small fragments collected in the western part of Building 2, in an area where the identification of other possible combustion features is hampered since the entire western part of the complex was burned.

Nowhere did we find any stone tools such as hammers or anvils, nor fragments of crucibles or moulds, nor copper slag. One can tentatively suggest this area was a place for copper storage and possibly for its handling during exchange.

## CONCLUSIONS

The two buried jars at Masafi-1 have been interpreted as caches containing a supply of raw copper, which may have been intended to be re-melted to produce objects. They suggest that the collective buildings of Masafi-1, like that of Muweilah, played an active role in the control or distribution of copper which, despite its relative frequency in the region, was probably a valuable product. They most probably testify to the presence of a metallurgical activity in the vicinity of the site, a production from which the community of Masafi benefited. Small copper-base fragments were found in the western part of Building 2. This is also comparable to Building II at Muweilah, as for both there is insufficient evidence of an on-site metallurgical workshop – either for metal refining or artefact production – rather than simply a place to store material recovered elsewhere.

Did the two jars with the Masafi-1 ingots serve as a supply of raw material, or were they intended as foundation deposits or symbolic offerings? The question remains open. Offering deposits including raw products or even waste from copper production have been recorded at other sites. At Bithnah they included copper prills probably recovered from the furnace itself, buried in a jar decorated with snakes in front of a low altar shaped as a coiled snake.<sup>51</sup> It was also accompanied by a small pile of slag placed in front of the head of the snake. But symbolic deposits at Bithnah were of relatively small size, whereas at Masafi-1, the quantity of hidden metal (c. 120kg of raw metal in jar MSF-2098 and 40kg in jar MSF-955) seems to be too high for a simple symbolic foundation deposit, at least when compared to similar occurrences in SE Arabia.

As a whole, the detailed review of the context of discovery of these two buried jars only confirms the role of Building 2 in the distribution of copper but does not provide any

---

<sup>51</sup> Pillaut, Le Carlier, Ploquin 2013.

solid proof of metalworking in this place. It is tempting to believe that workshops were located in the vicinity, but there is no evidence of their presence within the excavated area. Further work in the Masafi area might shed new light on this question.

### Acknowledgements

<sup>14</sup>C dating analyses were made by the Centre de Datation par le Radiocarbone Jacques Evin, University of Lyon 1, Villeurbanne.

### References

- Al Tikriti, W.Y. 2002: The south-east Arabian origin of the *falaj* system, *PSArabStud* 32, 117–138
- Avanzini, A., Degli Esposti, M. (Eds) 2018: Husn Salut and the Iron Age of South-East Arabia. Excavations of the Italian Mission to Oman 2004–2014, *Arabia Antica* 15, Roma
- Batchelor, D.A.-F. 1992: Styles of metallic mineralization and their tectonic settings in the Sultanate of Oman, *Transactions of the Institution of Mining and Metallurgy, Section B, applied earth science* 101, 108–120
- Benoist, A. 2010a: Fouilles à Masāfi-3 en 2009 (Émirat de Fujayrah, Émirats Arabes Unis) : premières observations à propos d'un espace culturel de l'Âge du Fer nouvellement découvert en Arabie orientale, *PSArabStud* 40, 119–130
- Benoist, A. 2010b: Authority and religion in eastern Arabia during the Iron Age (1150–250 BC), [*in:*] Avanzini, A. (Ed.), *Eastern Arabia during the First Millennium BC*, *Arabia Antica* 6, Roma, 109–143
- Benoist, A. 2013: A green paradise. Economic strategies, collective practices and local ancestors of the Iron Age community of Masāfi (Emirate of Fujairah, UAE), *PSArabStud* 43, 47–62
- Benoist, A. (Ed.) 2013: La vallée de Bithnah au cours de l'Âge du Fer, *BAR-IS* 2510, *British Foundation for the Study of Arabia Monographs* 14, Oxford
- Benoist, A., Bernard, V., Brunet, O., Hamel, A. 2012a: The Iron Age occupation in Masafi: report on two seasons of excavations, [*in:*] Potts, D.T., Hellyer, P. (Eds), *Fifty years of Emirates archaeology. Proceedings of the Second International Conference on the Archaeology of the United Arab Emirates, London-Dubai-Abu Dhabi*, 149–161
- Benoist, A., Bernard, V., Charbonnier, J., Goy, J., Hamel, A., Sagory, T. 2012b: Une occupation de l'âge du Fer à Masafi. Travaux récents de la Mission archéologique française aux E.A.U. dans l'Émirat de Fujairah, *Arabian Humanities* 17, <https://doi.org/10.4000/cy.1803>
- Benoist, A., Le Carlier, C., Goy, J., Degli Esposti, M., Armbruster, B., Attaelmanan, G. 2015: Snake, copper, and water in south-eastern Arabian religion during the Iron Age: the Bithnah and Masāfi evidence, [*in:*] Arbach, M., Schiettecatte, J. (Eds), *Pre-Islamic South Arabia and its Neighbours: New Developments of Research. Proceedings of*



- the 17th Rencontres Sabéennes held in Paris, 6–8 June 2013, *BAR-IS 2740, British Foundation for the Study of Arabia Monographs 16*, Oxford, 21–36
- Boucharlat, R. 2003: Iron Age water-draining Galleries and the Iranian *Qanāt*, [in:] Potts, D.T., al Naboodah, H., Hellyer, P. (Eds), *Archaeology of the United Arab Emirates: Proceedings of the First International Conference on the Archaeology of the U.A.E.*, London, 161–172
- Boucharlat, R., Lombard, P. 2001: Le Bâtiment G de Rumeilah (oasis d’Al Ain). Remarques sur les salles à poteaux de l’Âge du Fer en Péninsule d’Oman, *Iranica Antiqua 36*, 213–238
- Bronk Ramsey, C. 2021: OxCal Program v4.4, Radiocarbon Accelerator Unit. University of Oxford, <https://c14.arch.ox.ac.uk/oxcal.html> (accessed October 2023)
- Charbonnier, J. 2011: Les systèmes d’irrigation en Arabie méridionale (IVe millénaire av. J.-C. – Ier millénaire ap. J.-C.), unpublished PhD thesis, University of Paris I, Paris
- Charbonnier, J., Purdue, L., Benoist, A. 2017: Taming Surface Water in Pre-Islamic South-east Arabia: Archaeological, Geoarchaeological, and Chronological Evidence of Runoff Water Channelling in Masāfi (UAE), *Journal of Field Archaeology 42/1*, 13–28, <https://doi.org/10.1080/00934690.2016.1256172>
- Corboud, P., Castella Cibilis, A.C., Hapka, R., Im-Obersteg, P. 1994: Archaeological Survey of Fujairah 3: 1993. Preliminary report on the 1993 campaign of the Archaeological Survey of Fujairah (United Arab Emirates), Genève
- Decruyenaere, D., Mashkour, M., Lidour, K., Debue, K., Sagory, T., Pellegrino, M.P., Charbonnier, J., Benoist, A. 2022: Late Bronze Age and Iron Age animal exploitation in Masāfi, Fujairah, UAE, *PSArabStud 51*, 123–140
- Genchi, F., Giardino, G. 2018: The field work, [in:] Yule, P.A., Gernez, G. (Eds), *Early Iron Age Metal-Working Workshop in the Empty Quarter, al-Zahirah Province, Sultanate of Oman, Universitätsforschungen zur prähistorischen Archäologie 316*, Bonn, 11–31
- Gernez, G., Jean, M., Benoist, A. 2017: The discovery of a new Iron Age ritual complex in central Oman: recent excavations near Ādam, *PSArabStud 47*, 101–117
- Glassner, J.J. 1989: Mesopotamian textual evidence on Magan/Makan in the third millennium B.C., [in:] Costa, P.M., Tosi, M. (Eds), *Oman Studies. Papers on the Archaeology and History of Oman, Serie orientale Roma 63*, Rome, 181–191
- Goy, J. 2019: La métallurgie du cuivre à l’âge du Fer en péninsule d’Oman : organisation et caractéristiques techniques, unpublished PhD thesis, University of Paris I, Paris
- Goy, J., Le Carlier de Veslud, C., Degli Esposti, M., Attaelmanan, A.G. 2013: Archaeometallurgical survey in the area of Masafi (Fujairah, UAE): preliminary data from an integrated programme of survey, excavation and physicochemical analyses, *PSArabStud 43*, 127–145
- Goy, J., Degli Esposti, M., Le Carlier de Veslud, C., Benoist, A. 2018: Archaeometallurgical research on Iron Age (1250–300 BCE) Copper Production in Northern Al-Hajjar mountains (Oman Peninsula), [in:] Ben-Yosef, E. (Ed.), *Mining for Ancient Copper*.

- Essay in Memory of Beno Rothenberg, *Monograph Series of the Sonia and Marco Nadler Institute of Archaeology* 37, Tel Aviv, 366–384
- Hauptmann, A., Weisgerber, G., Blackmann, H.G. 1988: Early Copper Metallurgy in Oman, [in:] Maddin, R. (Ed.), *The Beginning of Use of Metals and Alloys. Papers from the Second International Conference, Zhangzhou, China, 21–26 October 1986*, Cambridge, 34–51
- Lehner, J.W., Dumitru, I.A., Buffington, A., Dollarhide, E., Nathan, S., Paulsen, P., Young, M.L., Sivitskis, A.J., Wiig, F., Harrower, M.J. 2023: Iron Age Copper Metallurgy in Southeast Arabia: A Comparative Perspective, [in:] Ben-Yosef, E., Jones, I.W.N. (Eds), “And in Length of Days Understanding” (Job 12:12). *Essays on Archaeology in the Eastern Mediterranean and Beyond in Honor of Thomas E. Levy*, New York, 1391–1417
- Lombard, P. 1989: Âges du fer sans fer : le cas de la péninsule d’Oman au 1er millénaire avant J.-C., [in:] Fadh, T. (Ed.), *L’Arabie préislamique et son environnement historique et culturel : Actes du Colloque de Strasbourg 24–27 Juin, Travaux du centre de recherches sur le Proche-Orient et la Grèce antique* 10, Leiden, 25–37
- Magee, P. 2003: Columned Halls, Power and Legitimation in the Southeast Arabian Iron Age, [in:] Potts, D.T., al Naboodah, H., Hellyer, P. (Eds), *Archaeology of the United Arab Emirates: Proceedings of the First International Conference on the Archaeology of the U.A.E.*, London, 181–191
- Magee, P. 2014: *The Archaeology of Prehistoric Arabia*, Cambridge
- Michel, J.C. (Ed.) 1993: Mineral occurrence and metallogenic map of north Oman (scale 1:1,000,000), Muscat
- Nashef, K. 2010: Sārūq al-Ḥadīd. An industrial Complex of the Iron Age II Period, [in:] Avanzini, A. (Ed.), *Eastern Arabian in the first millennium BC, Arabia Antica* 6, Rome, 213–226
- Pillaut, S., Le Carlier, C., Ploquin, A. 2013: Quelques interprétations paléométallurgiques à partir de l’analyse macroscopique, microscopique et chimiques de spécimens métalliques et scorifiés de Bithnah, [in:] Benoist, A. (Ed.), *La vallée de Bithnah au cours de l’Age du Fer, BAR-IS 2510, British Foundation for the Study of Arabia Monographs* 14, Oxford, 276–290
- Potts, D.T. 1990: *The Arabian Gulf in Antiquity, Vol. I: From Prehistory to the Fall of the Achaemenid Empire*, Oxford
- Power, T., Sheehan, P. 2011: Bayt Bin ‘Ātī in Qaṭṭārah Oasis: A prehistoric industrial site and the formation of the oasis landscape of al-‘Ain, UAE, *PSArabStud* 41, 267–282
- Qandil, H. 2003: Survey and excavations at Saruq al Hadeed, 2002–2003, [in:] Hellyer, P., Ziolkowski, M. (Eds), *Emirates Heritage: Proceedings of the 1st Annual Symposium on Recent Palaeontological and Archaeological Discoveries in the Emirates, Vol. 1, Al Ain*, 121–139
- Reimer, P.J., Austin, W.E.N., Bard, E., Bayliss, A., Blackwell, P., Bronk Ramsey, C., Butzin, M., Cheng, H., Edwards, R.L., Friedrich, M., Grootes, P.M., Guilderson, T.P., Hajdas, I., Heaton, T.J., Hogg, A.G., Hughen, K.A., Kromer, B., Manning, S.W., Muscheler, R.,

- Palmer, J.G., Pearson, C., van der Plicht, J., Reimer, R.W., Richards, D.A., Scott, E.M., Southon, J.R., Turney, C.S.M., Wacker, L., Adolphi, F., Büntgen, U., Capano, M., Fahrni, S.M., Fogtmann-Schulz, A., Friedrich, R., Köhler, P., Kudsk, S., Miyake, F., Olsen, J., Reinig, F., Sakamoto, M., Sookdeo, A., Talamo, S. 2020: The IntCal20 Northern Hemisphere radiocarbon age calibration curve (0–55 cal kBP), *Radiocarbon* 62/4, 725–757
- Sasso, M. 2018: Metal Objects, [in:] Avanzini, A., Degli Esposti, M. (Eds), Husn Salut and the Iron Age of South East Arabia. Excavations of the Italian Mission to Oman 2004–2014, *Arabia Antica* 15, Roma, 301–323
- Weeks, L.R. 1997: Prehistoric metallurgy at Tell Abraq, U.A.E., *AAE* 8/1, 11–35
- Weeks, L. 2003: Early Metallurgy of the Persian Gulf. Technology, Trade and the Bronze Age World, *American School of Prehistoric Research Monograph Series 2*, Boston
- Weeks, L., Cable, C., Franke, K., Newton, C., Karacic, S., Roberts, J., Stepanov, I., David-Cuny, H., Price, D., Bukhash, R.M., Radwan, M.B., Zein, H. 2017: Recent archaeological research at Saruq al-Hadid, Dubai, UAE, *AAE* 28/1, 31–60
- Weisgerber, G. 1980: „... und Kupfer in Oman“. Das Oman Projekt des Deutsches Bergbaumuseum, *Der Anschnitt* 32, 62–110
- Weisgerber, G. 1981: Mehr als Kupfer in Oman. Ergebnisse des Expedition 1981, *Der Anschnitt* 33/5–6, 174–263
- Yule, P., Weisgerber, G. 1999: Preliminary Report on the 1996 Season of Excavations in the Sultanate of Oman, [in:] Yule, P. (Ed.), Studies in the Archaeology of the Sultanate of Oman, *Orient Archäologie* 2, Rahden, 97–117